

NFPA[®]

170

**Standard for Fire Safety
and Emergency Symbols**

2018



All NFPA STANDARDS

 EDUFIRE_NFPA

 EDUFIRE.IR

FREE
2019



IMPORTANT NOTICES AND DISCLAIMERS CONCERNING NFPA® STANDARDS

NOTICE AND DISCLAIMER OF LIABILITY CONCERNING THE USE OF NFPA STANDARDS

NFPA® codes, standards, recommended practices, and guides (“NFPA Standards”), of which the document contained herein is one, are developed through a consensus standards development process approved by the American National Standards Institute. This process brings together volunteers representing varied viewpoints and interests to achieve consensus on fire and other safety issues. While the NFPA administers the process and establishes rules to promote fairness in the development of consensus, it does not independently test, evaluate, or verify the accuracy of any information or the soundness of any judgments contained in NFPA Standards.

The NFPA disclaims liability for any personal injury, property, or other damages of any nature whatsoever, whether special, indirect, consequential or compensatory, directly or indirectly resulting from the publication, use of, or reliance on NFPA Standards. The NFPA also makes no guaranty or warranty as to the accuracy or completeness of any information published herein.

In issuing and making NFPA Standards available, the NFPA is not undertaking to render professional or other services for or on behalf of any person or entity. Nor is the NFPA undertaking to perform any duty owed by any person or entity to someone else. Anyone using this document should rely on his or her own independent judgment or, as appropriate, seek the advice of a competent professional in determining the exercise of reasonable care in any given circumstances.

The NFPA has no power, nor does it undertake, to police or enforce compliance with the contents of NFPA Standards. Nor does the NFPA list, certify, test, or inspect products, designs, or installations for compliance with this document. Any certification or other statement of compliance with the requirements of this document shall not be attributable to the NFPA and is solely the responsibility of the certifier or maker of the statement.

REMINDER: UPDATING OF NFPA STANDARDS

Users of NFPA codes, standards, recommended practices, and guides (“NFPA Standards”) should be aware that NFPA Standards may be amended from time to time through the issuance of a Tentative Interim Amendment (TIA) or corrected by Errata. An official NFPA Standard at any point in time consists of the current edition of the document together with any TIAs and Errata then in effect.

To determine whether an NFPA Standard has been amended through the issuance of Tentative Interim Amendments or corrected by Errata, go to www.nfpa.org/docinfo to choose from the list of NFPA Standards or use the search feature to select the NFPA Standard number (e.g., NFPA 13). The document information page provides up-to-date document-specific information as well as postings of all existing TIAs and Errata. It also includes the option to register for an “Alert” feature to receive an automatic email notification when new updates and other information are posted regarding the document.

IMPORTANT NOTICES AND DISCLAIMERS CONCERNING NFPA® STANDARDS

ADDITIONAL NOTICES AND DISCLAIMERS

Updating of NFPA Standards

Users of NFPA codes, standards, recommended practices, and guides (“NFPA Standards”) should be aware that these documents may be superseded at any time by the issuance of new editions or may be amended from time to time through the issuance of Tentative Interim Amendments or corrected by Errata. An official NFPA Standard at any point in time consists of the current edition of the document together with any Tentative Interim Amendments and any Errata then in effect. In order to determine whether a given document is the current edition and whether it has been amended through the issuance of Tentative Interim Amendments or corrected through the issuance of Errata, consult appropriate NFPA publications such as the National Fire Codes® Subscription Service, visit the NFPA website at www.nfpa.org, or contact the NFPA at the address listed below.

Interpretations of NFPA Standards

A statement, written or oral, that is not processed in accordance with Section 6 of the Regulations Governing the Development of NFPA Standards shall not be considered the official position of NFPA or any of its Committees and shall not be considered to be, nor be relied upon as, a Formal Interpretation.

Patents

The NFPA does not take any position with respect to the validity of any patent rights referenced in, related to, or asserted in connection with an NFPA Standard. The users of NFPA Standards bear the sole responsibility for determining the validity of any such patent rights, as well as the risk of infringement of such rights, and the NFPA disclaims liability for the infringement of any patent resulting from the use of or reliance on NFPA Standards.

NFPA adheres to the policy of the American National Standards Institute (ANSI) regarding the inclusion of patents in American National Standards (“the ANSI Patent Policy”), and hereby gives the following notice pursuant to that policy:

NOTICE: The user’s attention is called to the possibility that compliance with an NFPA Standard may require use of an invention covered by patent rights. NFPA takes no position as to the validity of any such patent rights or as to whether such patent rights constitute or include essential patent claims under the ANSI Patent Policy. If, in connection with the ANSI Patent Policy, a patent holder has filed a statement of willingness to grant licenses under these rights on reasonable and nondiscriminatory terms and conditions to applicants desiring to obtain such a license, copies of such filed statements can be obtained, on request, from NFPA. For further information, contact the NFPA at the address listed below.

Law and Regulations

Users of NFPA Standards should consult applicable federal, state, and local laws and regulations. NFPA does not, by the publication of its codes, standards, recommended practices, and guides, intend to urge action that is not in compliance with applicable laws, and these documents may not be construed as doing so.

Copyrights

NFPA Standards are copyrighted. They are made available for a wide variety of both public and private uses. These include both use, by reference, in laws and regulations, and use in private self-regulation, standardization, and the promotion of safe practices and methods. By making these documents available for use and adoption by public authorities and private users, the NFPA does not waive any rights in copyright to these documents.

Use of NFPA Standards for regulatory purposes should be accomplished through adoption by reference. The term “adoption by reference” means the citing of title, edition, and publishing information only. Any deletions, additions, and changes desired by the adopting authority should be noted separately in the adopting instrument. In order to assist NFPA in following the uses made of its documents, adopting authorities are requested to notify the NFPA (Attention: Secretary, Standards Council) in writing of such use. For technical assistance and questions concerning adoption of NFPA Standards, contact NFPA at the address below.

For Further Information

All questions or other communications relating to NFPA Standards and all requests for information on NFPA procedures governing its codes and standards development process, including information on the procedures for requesting Formal Interpretations, for proposing Tentative Interim Amendments, and for proposing revisions to NFPA standards during regular revision cycles, should be sent to NFPA headquarters, addressed to the attention of the Secretary, Standards Council, NFPA, 1 Batterymarch Park, P.O. Box 9101, Quincy, MA 02269-9101; email: stds_admin@nfpa.org.

For more information about NFPA, visit the NFPA website at www.nfpa.org. All NFPA codes and standards can be viewed at no cost at www.nfpa.org/docinfo.

Copyright © 2017 National Fire Protection Association®. All Rights Reserved.

NFPA® 170

Standard for

Fire Safety and Emergency Symbols

2018 Edition

This edition of NFPA 170, *Standard for Fire Safety and Emergency Symbols*, was prepared by the Technical Committee on Fire Safety and Emergency Symbols. It was issued by the Standards Council on April 3, 2017, with an effective date of April 23, 2017, and supersedes all previous editions.

This edition of NFPA 170 was approved as an American National Standard on April 23, 2017.

Origin and Development of NFPA 170

The 1994 edition of NFPA 170 represented the completion of an effort to combine four previously separate documents that covered fire safety symbols for different purposes. These documents were the following:

NFPA 171, *Public Firesafety Symbols*

NFPA 172, *Fire Protection Symbols for Architectural and Engineering Drawings*

NFPA 174, *Fire Protection Symbols for Risk Analysis Diagrams*

NFPA 178, *Symbols for Fire Fighting Operations*

The Technical Committee on Fire Safety Symbols believed that placing all fire safety symbols in one document made it easier for users of symbols to find the one(s) most appropriate for their application. It also eliminated duplication between these and eventually other NFPA documents.

The first edition of NFPA 170, in 1991, placed these four documents in one document but did not combine them, except for definitions that were in each document.

For the second edition of NFPA 170, in 1994, the Technical Committee on Fire Safety Symbols completely restructured the text into a logical and cohesive arrangement. The duplication of symbols that occurred during the aforementioned consolidation of documents was eliminated. New symbols added included those for *campfire prohibitions, smoke barriers, illuminated exit signs, and belowground tanks*.

For the third (1996) edition of NFPA 170, changes included the following:

- (1) Upgrading recommendations on *pre-incident planning* to requirements
- (2) Adding new symbols for *pull station, area of refuge, and cooking prohibition*
- (3) Clarifying the symbols for *smoke detectors, battery-powered emergency lights, and fire service/emergency telephone station*
- (4) Recognizing the phaseout of Halon now taking place and the introduction of *clean agents*

The 1999 edition further recognized the introduction of clean agents by adding new symbols for *clean agent* and *water mist systems*. A new appendix (Appendix C) was added to include symbols that can be used for life safety planning.

The 2002 edition was reformatted to conform to the *Manual of Style for NFPA Technical Committee Documents*. Symbols for fire alarm system components were added for consistency with *NFPA 72®*, *National Fire Alarm Code®*.

In 2004, the scope of the committee was expanded to include emergency symbols to allow emergency mapping symbols in a new Chapter 8.

The 2006 edition of NFPA 170 included the refinement of exit symbology for better recognition of exit, arrow, and flame symbols that are consistent with international standards.

A new Chapter 8, Symbology for Emergency Management Mapping, was added to assist the user in the preparation for, prevention of, protection against, response to, and recovery from threats to the nation's population centers and critical infrastructure from terrorist, criminal, accidental, or natural origin.

The symbols in Chapter 8 were the result of efforts by the Federal Geographic Data Committee — Homeland Security Working Group (<http://www.fgdc.gov/fgdc/homeland/index.html>). The symbols were included in the 2006 edition so that they can be processed through an accredited standards-writing organization and made available to the public.

The 2009 edition of NFPA 170 included a new chapter (Chapter 9) that provided guidance on the development of emergency evacuation diagrams and plans.

The 2012 edition of NFPA 170 included a new Chapter 7 and a new Chapter 8, previously all encompassed within the old Chapter 6. This affected symbol detail for various device symbols such as fire alarm devices, fire sprinkler devices, electronic fire and smoke detection, and so forth. This action better organized existing symbols within the standard for the user.

The 2015 edition revised several symbols for consistency and clarity. The “wisp of smoke” was replaced by an “S” to simplify the symbol when viewed on plans. Many tables were reorganized for clarity and ease of use as well.

In the 2018 edition, the tornado symbol has been added, and several references have been updated. The term *smoke barrier* has been changed to *smoke rated*, and the term *fire barrier* has been changed to *fire rated*. More details have been added to the symbols for a fire department connection. A distinction has been made between water-driven and electric-driven water flow alarms.

Technical Committee on Fire Safety and Emergency Symbols

James M. Mundy, Jr., *Chair*

Asset Protection Associates, Ltd., NY [M]
Rep. Automatic Fire Alarm Association, Inc.

Scott Bailey, Koorsen Fire & Security, IN [M]
Rep. Fire Suppression Systems Association

Cecil Bilbo, Jr., Academy of Fire Sprinkler Technology, Inc., IL [SE]

Thomas F. Bresnahan, BC Associates, IL [SE]
Rep. American Society of Safety Engineers

Chris L. Butts, Pond & Company, GA [SE]

David C. Cox, Fire Safety Displays Company, MI [M]

Patrick T. Earley, New Brunswick Fire Department, NJ [U]

Aaron C. Jones, GHD Inc., MD [SE]

Stephen P. Rinaldi, Los Alamos County Fire Department, NM [E]

Keith R. Salzman, Clear Air Force Station Fire Department, AK [U]

Brad Schiffer, Brad Schiffer/Taxis, Inc., FL [SE]

William D. Smith, PASCO - Palmetto Automatic Sprinkler Co., GA [M]

Christopher Willms, Sea Girt Fire Company #1, NJ [E]

Thomas R. Wood, Boca Raton Fire Rescue Services, FL [E]

Alternates

Thomas E. Heebner, HUB International, IL [SE]
(Alt. to Thomas F. Bresnahan)

Romil Patel, Siemens Building Technologies, Inc., NJ [M]
Rep. National Electrical Manufacturers Association
(Voting Alt.)

Thomas G. Wellen, American Fire Sprinkler Association, Inc., TX [IM]

(Voting Alt.)

Richard P. Bielen, NFPA Staff Liaison

This list represents the membership at the time the Committee was balloted on the final text of this edition. Since that time, changes in the membership may have occurred. A key to classifications is found at the back of the document.

NOTE: Membership on a committee shall not in and of itself constitute an endorsement of the Association or any document developed by the committee on which the member serves.

Committee Scope: This Committee shall have primary responsibility for documents on fire safety and emergency symbols including those for building design plans, investigation diagrams, maps, and for public fire safety and emergency. It shall coordinate its work with NFPA technical committees and other groups dealing with subjects to which fire safety symbols apply.

Contents

Chapter 1 Administration	170- 5	8.2 Symbols for Control Panels.	170- 29
1.1 Scope.	170- 5	8.3 Symbols for Fire Alarms, Detection, and Related Equipment — Signal Initiating Devices and Activation Switches.	170- 30
1.2 Purpose.	170- 5	8.4 Notification Appliances.	170- 32
1.3 Retroactivity.	170- 5	8.5 Related Equipment.	170- 33
1.4 Equivalency.	170- 5	8.6 Symbols for Smoke/Pressurization Control.	170- 34
1.5 Units.	170- 5		
Chapter 2 Referenced Publications	170- 5	Chapter 9 Symbols for Use in Pre-Incident Planning Sketches	170- 34
2.1 General.	170- 5	9.1 Introduction.	170- 34
2.2 NFPA Publications.	170- 5	9.2 Access Features, Assessment Features, Ventilation Features, and Utility Shutoffs.	170- 34
2.3 Other Publications.	170- 5	9.3 Detection/Extinguishing Equipment.	170- 34
2.4 References for Extracts in Mandatory Sections.	170- 6	9.4 Water Flow Control Valves and Water Sources. .	170- 34
Chapter 3 Definitions	170- 6	9.5 Equipment Rooms.	170- 34
3.1 General.	170- 6	9.6 Identification of Hazardous Materials.	170- 34
3.2 NFPA Official Definitions.	170- 6		
3.3 General Definitions.	170- 6	Chapter 10 Symbology for Emergency Management Mapping	170- 37
Chapter 4 Symbols for General Use	170- 7	10.1 Damage Operational Symbols.	170- 37
4.1 Introduction.	170- 7	10.2 Operations Symbology.	170- 37
4.2 Symbols for General Use.	170- 7	10.3 Incidents Symbology.	170- 37
4.3 Class of Fire Symbols.	170- 7	10.4 Natural Events Symbology.	170- 37
Chapter 5 Symbols for Use by the Fire Service	170- 14	10.5 Infrastructures Symbology.	170- 37
5.1 Introduction.	170- 14		
5.2 Symbols for Use by the Fire Service.	170- 14	Chapter 11 Emergency Evacuation Diagrams and Plans	170- 57
5.3 Fire Apparatus Safety Symbols.	170- 14	11.1 Introduction.	170- 57
Chapter 6 Symbols for Use in Architectural and Engineering Drawings and Insurance Diagrams	170- 18	11.2 Composition.	170- 57
6.1 Introduction.	170- 18	11.3 Orientation.	170- 57
6.2 Symbols for Site Features.	170- 18	11.4 Information Shown.	170- 57
6.3 Symbols for Building Construction.	170- 18	11.5 Construction.	170- 57
Chapter 7 Symbols for Use in Water Supply, Extinguishing, and Sprinkler System Drawings and Insurance Diagrams	170- 21	Annex A Explanatory Material	170- 57
7.1 Introduction.	170- 21	Annex B Additional Explanatory Information on Chapters 1 Through 6	170- 62
7.2 Water Supply and Distribution Symbols.	170- 21	Annex C Emergency Responder Map	170- 66
7.3 Reserved.	170- 21	Annex D Fire Fighter Safety Building Marking System	170- 69
7.4 Symbols Related to Means of Egress.	170- 21	Annex E Informational References	170- 70
7.5 Indicating Appliances.	170- 21	Index	170- 72
7.6 Symbols for Fire Extinguishing Systems.	170- 21		
7.7 Symbols for Portable Fire Extinguishers.	170- 21		
7.8 Symbols for Fire-Fighting Equipment.	170- 21		
7.9 Miscellaneous Symbols.	170- 21		
Chapter 8 Symbols for Use in Electronic Fire and Smoke Detection and Notification System Drawings and Insurance Diagrams	170- 29		
8.1 Introduction.	170- 29		

NFPA 170

Standard for

Fire Safety and Emergency Symbols

2018 Edition

IMPORTANT NOTE: This NFPA document is made available for use subject to important notices and legal disclaimers. These notices and disclaimers appear in all publications containing this document and may be found under the heading “Important Notices and Disclaimers Concerning NFPA Standards.” They can also be viewed at www.nfpa.org/disclaimers or obtained on request from NFPA.

UPDATES, ALERTS, AND FUTURE EDITIONS: New editions of NFPA codes, standards, recommended practices, and guides (i.e., NFPA Standards) are released on scheduled revision cycles. This edition may be superseded by a later one, or it may be amended outside of its scheduled revision cycle through the issuance of Tentative Interim Amendments (TIAs). An official NFPA Standard at any point in time consists of the current edition of the document, together with all TIAs and Errata in effect. To verify that this document is the current edition or to determine if it has been amended by TIAs or Errata, please consult the National Fire Codes® Subscription Service or the “List of NFPA Codes & Standards” at www.nfpa.org/docinfo. In addition to TIAs and Errata, the document information pages also include the option to sign up for alerts for individual documents and to be involved in the development of the next edition.

NOTICE: An asterisk (*) following the number or letter designating a paragraph indicates that explanatory material on the paragraph can be found in Annex A.

A reference in brackets [] following a section or paragraph indicates material that has been extracted from another NFPA document. As an aid to the user, the complete title and edition of the source documents for extracts in mandatory sections of the document are given in Chapter 2 and those for extracts in informational sections are given in Annex E. Extracted text may be edited for consistency and style and may include the revision of internal paragraph references and other references as appropriate. Requests for interpretations or revisions of extracted text shall be sent to the technical committee responsible for the source document.

Information on referenced publications can be found in Chapter 2 and Annex E.

Chapter 1 Administration

1.1 Scope. This standard presents symbols used for fire safety, emergency, and associated hazards.

1.2 Purpose. The purpose of this standard is to standardize the symbols used in representing fire safety, emergency, and associated hazards.

1.3 Retroactivity. The provisions of this standard reflect a consensus of what is necessary to provide an acceptable degree of protection from the hazards addressed in this standard at the time the standard was issued.

1.3.1 Unless otherwise specified, the provisions of this standard shall not apply to facilities, equipment, structures, or installations that existed or were approved for construction or installation prior to the effective date of the standard. Where specified, the provisions of this standard shall be retroactive.

1.3.2 In those cases where the authority having jurisdiction determines that the existing situation presents an unacceptable degree of risk, the authority having jurisdiction shall be permitted to apply retroactively any portions of this standard deemed appropriate.

1.3.3 The retroactive requirements of this standard shall be permitted to be modified if their application clearly would be impractical in the judgment of the authority having jurisdiction, and only where it is clearly evident that a reasonable degree of safety is provided.

1.4 Equivalency. Nothing in this standard is intended to prevent the use of systems, methods, or devices of equivalent or superior quality, strength, fire resistance, effectiveness, durability, and safety over those prescribed by this standard.

1.4.1 Technical documentation shall be submitted to the authority having jurisdiction to demonstrate equivalency.

1.4.2 The system, method, or device shall be approved for the intended purpose by the authority having jurisdiction.

1.5 Units. Metric units of measurement used in this standard shall be in accordance with the International System of Units (SI). One unit (liter), outside of but recognized by SI, is commonly used in international fire protection. For conversion factors, see Table 1.5.

Table 1.5 Metric Conversion Factors

Name of Unit	Unit Symbol	Conversion Factor
Liter	L	1 gal = 3.785 L
Cubic decimeter	dm ³	1 gal = 3.785 dm ³
Pascal	Pa	1 psi = 6894.757 Pa
Meter	m	1 ft = 0.3048 m
Millimeter	mm	1 in. = 25.4 mm

Chapter 2 Referenced Publications

2.1 General. The documents or portions thereof listed in this chapter are referenced within this standard and shall be considered part of the requirements of this document.

2.2 NFPA Publications. National Fire Protection Association, 1 Batterymarch Park, Quincy, MA 02169-7471.

NFPA 101®, *Life Safety Code*®, 2015 edition.

NFPA 704, *Standard System for the Identification of the Hazards of Materials for Emergency Response*, 2017 edition.

2.3 Other Publications.

2.3.1 ANSI Publications. American National Standards Institute, Inc., 25 West 43rd Street, 4th Floor, New York, NY 10036.

ICC/ANSI A117.1, *Accessible and Usable Buildings and Facilities*, 2009.

ANSI Z535.1, *Safety Color Code*, 2011.

2.3.2 ASTM Publications. ASTM International, 100 Barr Harbor Drive, P.O. Box C700, West Conshohocken, PA 19428-2959.

ASTM E2072, *Standard Specification for Photoluminescent (Phosphorescent) Safety Markings*.

ASTM E2073, *Standard Test Method for Photopic Luminance of Photoluminescent (Phosphorescent) Markings*.

2.3.3 FAMA Publications. Fire Apparatus Manufacturers Association, P.O. Box 397, Lynnfield, MA 01940.

FAMA TC00, *Graphical Symbols for Automotive Fire Apparatus*, 2014-10.

FAMA TC010, *Standard Product Safety Sign Catalog for Automotive Fire Apparatus*, 2012.

2.3.4 NECA Publications. National Electrical Contractors Association, 3 Bethesda Metro Center, Suite 1100, Bethesda, MD 20814.

NECA NEIS 100, *Symbols for Electrical Construction Drawings*, 2013.

2.3.5 UL Publications. Underwriters Laboratories Inc., 333 Pfingsten Road, Northbrook, IL 60062-2096.

UL 924, *Standard for Emergency Lighting and Power Equipment*, 2006.

ANSI/UL 1994, *Standard for Luminous Egress Path Marking Systems*.

2.3.6 Other Publications.

Merriam-Webster's Collegiate Dictionary, 11th edition, Merriam-Webster, Inc., Springfield, MA, 2003.

2.4 References for Extracts in Mandatory Sections.

NFPA 10, *Standard for Portable Fire Extinguishers*, 2017 edition.

Chapter 3 Definitions

3.1 General. The definitions contained in this chapter shall apply to the terms used in this standard. Where terms are not defined in this chapter or within another chapter, they shall be defined using their ordinarily accepted meanings within the context in which they are used. *Merriam-Webster's Collegiate Dictionary*, 11th edition, shall be the source for the ordinarily accepted meaning.

3.2 NFPA Official Definitions.

3.2.1 Approved. Acceptable to the authority having jurisdiction.

3.2.2* Authority Having Jurisdiction (AHJ). An organization, office, or individual responsible for enforcing the requirements of a code or standard, or for approving equipment, materials, an installation, or a procedure.

3.2.3 Labeled. Equipment or materials to which has been attached a label, symbol, or other identifying mark of an organization that is acceptable to the authority having jurisdiction

and concerned with product evaluation, that maintains periodic inspection of production of labeled equipment or materials, and by whose labeling the manufacturer indicates compliance with appropriate standards or performance in a specified manner.

3.2.4* Listed. Equipment, materials, or services included in a list published by an organization that is acceptable to the authority having jurisdiction and concerned with evaluation of products or services, that maintains periodic inspection of production of listed equipment or materials or periodic evaluation of services, and whose listing states that either the equipment, material, or service meets appropriate designated standards or has been tested and found suitable for a specified purpose.

3.2.5 Shall. Indicates a mandatory requirement.

3.2.6 Should. Indicates a recommendation or that which is advised but not required.

3.2.7 Standard. An NFPA Standard, the main text of which contains only mandatory provisions using the word "shall" to indicate requirements and that is in a form generally suitable for mandatory reference by another standard or code or for adoption into law. Nonmandatory provisions are not to be considered a part of the requirements of a standard and shall be located in an appendix, annex, footnote, informational note, or other means as permitted in the NFPA Manuals of Style. When used in a generic sense, such as in the phrase "standards development process" or "standards development activities," the term "standards" includes all NFPA Standards, including Codes, Standards, Recommended Practices, and Guides.

3.3 General Definitions.

3.3.1 Photoluminescent. Having the property of emitting light that continues for a length of time after excitation by visible or invisible light has been removed. [UL 924: Section 202]

3.3.2 Pre-Incident Planning. A written document resulting from the gathering of general and detailed information/data to be used by public emergency response agencies and private industry for determining the response to reasonable anticipated emergency incidents at a specific facility.

3.3.3* Referent. An object or concept (message) represented by a symbol.

3.3.4 Self-Luminous (Emergency Symbols). A type of sign with an integral legend that is powered continuously by a self-contained energy source other than a battery, such as radioactive tritium gas. Operation of a self-luminous sign is independent of external power supplies or other external forms of energy. This definition does not include exit signs dependent upon photoluminescent materials. [UL 924: Section 202]

3.3.5* Supplementary Indicators. Figures, numbers, subscripts, or letter abbreviations used to enhance the effectiveness of symbols.

3.3.6* Symbol. A graphic representation of a referent.

Chapter 4 Symbols for General Use

4.1 Introduction.

4.1.1 This chapter presents general referents and symbols for fire prevention and visual alerting that shall be used for fire and related life safety emergencies.

4.1.2 Purpose.

4.1.2.1 This chapter shall provide uniform fire safety symbols to improve communication wherever signs and symbols are employed to provide fire safety information.

4.1.2.2 This chapter provides uniformity in the selection of symbols that shall be designed to assist in locating exits, fire safety alerting equipment, and safe areas.

4.1.2.3* The fundamental imagery for symbols, as well as their background color and shape, shall be designated in this chapter.

4.1.3* Symbol Presentation.

4.1.3.1 The orientation for prohibition symbols shall not be altered from that shown in this chapter.

4.1.3.2 The symbol background shape shall be as specified in Table 4.2.

4.1.3.2.1* For prohibition symbols, a circle and diagonal slash (at 45 degrees from upper left to lower right) shall be used.







4.1.3.3 Symbol Color. The symbol color shall meet the requirements of ANSI Z535.1, *Safety Color Code*.

4.1.3.4* Symbols shall be permitted to be used in combination with other symbols, either vertically or horizontally, on the same sign or on separate signs adjacent to each other.

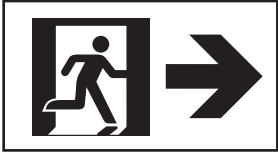
4.2* Symbols for General Use. The symbols for general use shall be as given in Table 4.2.



4.3 Class of Fire Symbols. The symbols for class of fire shall be as given in Figure 4.3(a) and Figure 4.3(b).

Table 4.2 Symbols for General Use

Symbol	Characteristics	Application	Example
<p>Emergency Exit</p> 	<p>Square field Background green Door opening white Image in green</p>	<p>The identification and location of an emergency exit</p>	<p>The location of exit for use in a fire emergency</p>
<p>Emergency Exit Use of Arrows — Rectangular Field</p> 	<p>Painted version: Background color white Arrows red or black Backlit version: Doorway, arrows, and lettering in green or red</p>	<p>The identification and location of a route to an emergency exit</p>	<p>Progress to the right</p>
	<p>Painted version: Background color white Arrows red or black Backlit version: Doorway, arrows, and lettering in green or red</p>	<p>The identification and location of a route to an emergency exit</p>	<p>Progress up and to the right</p>
	<p>Painted version: Background color white Arrows red or black Backlit version: Doorway, arrows, and lettering in green or red</p>	<p>The identification and location of a route to an emergency exit</p>	<p>Progress down and to the right</p>
	<p>Painted version: Background color white Arrows red or black Backlit version: Doorway, arrows, and lettering in green or red</p>	<p>The identification and location of a route to an emergency exit</p>	<p>Progress forward</p>
	<p>Painted version: Background color white Arrows red or black Backlit version: Doorway, arrows, and lettering in green or red</p>	<p>The identification and location of a route to an emergency exit</p>	<p>Progress down</p>
	<p>Painted version: Background color white Arrows red or black Backlit version: Doorway, arrows, and lettering in green or red</p>	<p>The identification and location of a route to an emergency exit</p>	<p>Progress to the left</p>



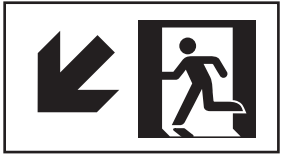

(continues)

Table 4.2 Continued

Symbol	Characteristics	Application	Example
	<p>Painted version: Background color white Arrows red or black</p> <p>Backlit version: Doorway, arrows, and lettering in green or red</p>	<p>The identification and location of a route to an emergency exit</p>	<p>Progress up and to the left</p>
	<p>Painted version: Background color white Arrows red or black</p> <p>Backlit version: Doorway, arrows, and lettering in green or red</p>	<p>The identification and location of a route to an emergency exit</p>	<p>Progress down and to the left</p>
<p>Emergency Exit Route (Combination of Two Symbols)</p> 	<p>Square field Background green Door opening white Image in green</p> <p>For arrows: Square field Green arrow on white background or white arrow on green background</p>	<p>The identification and location of a route to be used in an emergency</p>	<p>The direction to a fire exit</p>
<p>Accessible Emergency Exit (Combination of Two Symbols)</p> 	<p>Square field Background green Door opening white Image in green International symbol of accessibility per ICC/ANSI A117.1, <i>Accessible and Usable Buildings and Facilities</i></p>	<p>The identification of a route that leads to an emergency exit that is accessible to disabled users, as specified by ICC/ANSI A117.1, <i>Accessible and Usable Buildings and Facilities</i></p>	<p>The location of a route toward a fire exit that is accessible to disabled users</p>







(continues)

Table 4.2 *Continued*

Symbol	Characteristics	Application	Example
<p>Accessible Emergency Exit Route (Combination of Three Symbols)</p> 	<p>Square field Background green Door opening white Image in green</p> <p>International symbol of accessibility per ICC/ANSI A117.1, <i>Accessible and Usable Buildings and Facilities</i></p> <p>For arrows: Square field Green arrow on white background or white arrow on green background</p>	The identification of a route that leads to an emergency exit that is accessible to disabled users	The location of the route toward a fire exit that is accessible to disabled users
<p>Not an Exit</p> 	<p>Circular field Red prohibition symbol Background white Door frame green Door opening white Image in black</p>	The identification of doors that do NOT lead to an exit	The location of an interior door such as one leading to a closet, an interior courtyard, or a basement
<p>Use Stairs in Case of Fire</p> 	<p>Square field Red flame Black figure White background</p>	An instruction to the user to use stairs (downward egress) in case of fire	The identification that stairs are to be used in case of fire
<p>Use Stairs in Case of Fire</p> 	<p>Square field Red flame Black figure White background</p>	An instruction to the user to use stairs (upward egress) in case of fire	The identification that stairs are to be used in case of fire
<p>Do Not Use Elevator in Case of Fire</p> 	<p>Rectangular field Red flame Black figures White background Red circle and slash</p>	An instruction not to use elevators in case of fire	Posted near elevator call button







(continues)

Table 4.2 *Continued*

Symbol	Characteristics	Application	Example
<p>No Open Flame — Flame</p> 	<p>Circular field Red circle and slash Black image White background</p>	<p>The identification of areas in which open flame is prohibited</p>	<p>The identification of areas, such as combustible storage areas, gas stations, and hazardous areas</p>
<p>No Open Flame — Lighted Match</p> 	<p>Circular field Red circle and slash Black image White background</p>	<p>An instruction not to use lighted matches</p>	<p>Where posted, the use of matches is prohibited</p>
<p>No Smoking</p> 	<p>Circular field Red circle and slash Black image White background</p>	<p>The identification of areas in which smoking is prohibited</p>	<p>The identification of areas, such as those for flammable liquid storage, where smoking could lead to fire or explosion</p>
<p>No Campfires</p> 	<p>Circular field Red circle and slash Black image White background</p>	<p>The identification of areas where campfires are not permitted</p>	<p>The identification of areas, such as municipal parks, where campfires are not permitted</p>
<p>Manual Station — Pull Station/Fire Alarm Box</p> 	<p>Rectangular field Red background White flame White hand White box White horn</p>	<p>An instruction to actuate an alarm-initiating device in a fire emergency</p>	<p>Posted above a manually activated initiating device</p>
<p>No Cooking</p> 	<p>Square field White background Red flame Black pot and steam Red circle and slash</p>	<p>An instruction not to cook food in an area</p>	<p>Posted inside a guest room in a hotel or a student room in a college dormitory</p>

(continues)

Table 4.2 Continued

Symbol	Characteristics	Application	Example
Area of Refuge 	Square field White background Red flame	The identification of an area of refuge	A designated area of refuge to be used in a fire emergency
Severe Weather Shelter Area 	Background yellow Figures black Black storm symbol	The identification for a severe weather shelter. Include appropriate symbol for type of storm anticipated (e.g., cyclone, tornado)	Tornado shelter
No Hanger 	Red circle and slash Black image	To prohibit hanging clothes or other items from sprinklers	Where posted
Automated External Defibrillator (AED) 	Square field White background Red heart White bolt through the heart Black lettering	To identify the location of AEDs	Posted in airports and other places of assembly
Fire Extinguisher 	Square field Red background White symbol	For everyday use in workplaces and public areas; supplementary text sign can be used to increase comprehension	Fire safety signage, manuals, and notices
Fire Hose or Standpipe 	Square field Red background White symbol	For everyday use in workplaces and public areas; supplementary text sign can be used to increase comprehension	Fire safety signage, manuals, and notices

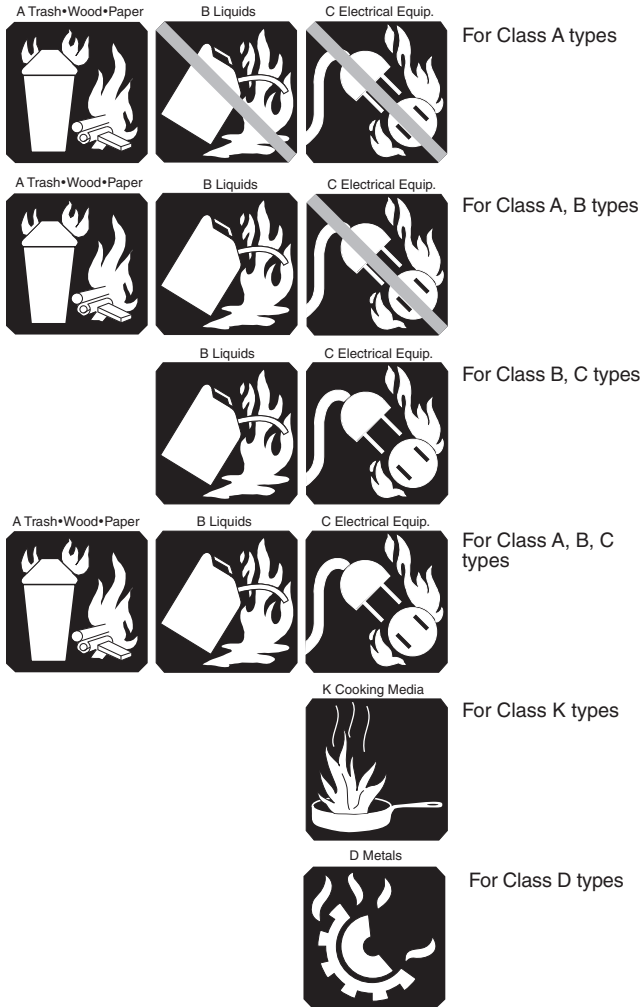

Note: Recommended colors, per PMS (Pantone Matching System) include the following:

- BLUE — 299
- RED — Warm Red

FIGURE 4.3(a) Recommended Marking System. [10:Figure B.1.1]

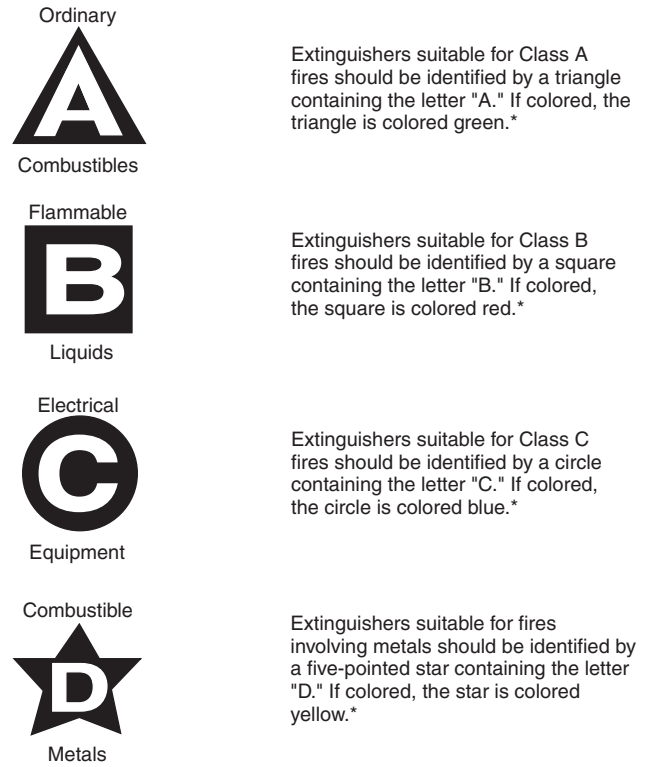

* Recommended colors, per PMS (Pantone Matching System) include the following:

- GREEN — Basic Green
- RED — 192 Red
- BLUE — Process Blue
- YELLOW — Basic Yellow

FIGURE 4.3(b) Letter-Shaped Symbol Markings. [10:Figure B.2.2]

Chapter 5 Symbols for Use by the Fire Service

5.1 Introduction.

5.1.1* This chapter presents standard referents and symbols that shall be used for visually alerting fire fighters and other emergency responders during fire and related emergencies.

5.1.2* Fundamental shapes of symbols, as well as the background color and shape, shall be as designated in this chapter.

5.1.3* Symbol Presentation.

5.1.3.1* Symbol Shapes. The shape of symbols shall be as illustrated in Section 5.2.

5.1.3.2 Symbol Background.

5.1.3.2.1 The symbol background shall be as specified in Table 5.2.

5.1.3.2.2 The symbol background color shall be red, white, or blue as designated and shall meet the requirements of ANSI Z535.1, *Safety Color Code*, for safety red, white, or blue.





5.1.3.3 Symbol Color. The symbol color shall be safety white or blue and shall meet the requirements of ANSI Z535.1, *Safety Color Code*, for safety white or blue.

5.1.3.4 Symbol Orientation. Symbol orientation shall not be altered from that shown in this chapter.

5.2* Symbols for Use by the Fire Service. The symbols for use by the fire service shall be as given in Table 5.2.

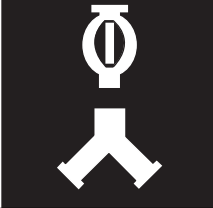

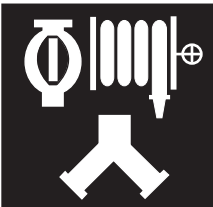

5.3 Fire Apparatus Safety Symbols. Safety signs referenced in this standard beginning with the letters FAMA shall conform to the text and graphics of the referenced safety sign number found in FAMA TC010, *Standard Product Safety Sign Catalog for Automotive Fire Apparatus*.

Table 5.2 Symbols for Use by the Fire Service

Symbol	Characteristics	Application	Examples
<p>Fire Department Automatic Sprinkler Connection — Siamese</p> 	<p>Square field Red background White symbol</p>	<p>The identification and location of a fire department automatic sprinkler connection</p>	<p>The location of a siamese automatic sprinkler connections on buildings The location of siamese freestanding automatic sprinkler connections</p>
<p>Fire Department Automatic Sprinkler Connection — Single</p> 	<p>Square field Red background White symbol</p>	<p>The identification and location of a fire department automatic sprinkler connection</p>	<p>The location of a single automatic sprinkler connection on buildings The location of a single freestanding automatic sprinkler connection</p>
<p>Fire Department Standpipe Connection</p> 	<p>Square field Red background White symbol</p>	<p>The identification and location of a fire department standpipe connection</p>	<p>The location of standpipe connections on buildings and structures The location of freestanding standpipe connections</p>
<p>Fire Department Combined Automatic Sprinkler/Standpipe Connection</p> 	<p>Square field Red background White symbol</p>	<p>The identification and location of a fire department combined automatic sprinkler/standpipe connection</p>	<p>The location of combined sprinkler/standpipe connections on buildings The location of freestanding combined sprinkler/standpipe connections</p>
<p>Fire Hydrant (All Types)</p> 	<p>Square field Red background White symbol</p>	<p>The identification and location of a fire hydrant</p>	<p>The location of fire hydrants, wall hydrants, underground hydrants, or other fire-fighting water supplies</p>



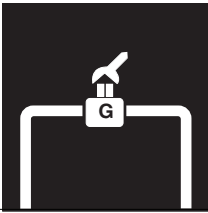
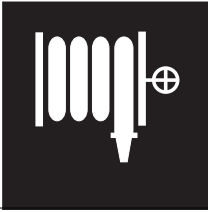

(continues)

Table 5.2 *Continued*

Symbol	Characteristics	Application	Examples
Automatic Sprinkler Control Valve 	Square field Red background White symbol	The identification and location of an automatic sprinkler control valve	The location of control valves for automatic sprinkler systems On doors of rooms containing control valves
Electric Panel or Electric Shutoff 	Square field Blue background White symbol	The identification and location of an electrical panel or other electric shutoff device	The location of electric panels or other electric control devices that can be located in basements or mechanical rooms
Gas Shutoff Valve 	Square field Red background White symbol Red letter G	The location of a gas shutoff valve	The location of gas shutoff valves On doors of rooms containing gas shutoff valves
Fire-Fighting Hose or Standpipe Outlet 	Square field Red background White symbol	The location of a fire-fighting hose or a standpipe outlet	The location of interior fire-fighting hose stations and standpipe outlets in buildings and structures The location on bridges or elevated highways
Fire Extinguisher 	Square field Red background White symbol	The location of a fire extinguisher	The location of fire extinguishers in buildings and exterior locations
Directional Arrow 	Square field Background green to correspond to accompanying sign White symbol	Direction to the location of fire-fighting equipment or utility; always used in conjunction with, and adjacent to, another symbol indicating the particular equipment or utility	

(continues)

Table 5.2 *Continued*

Symbol	Characteristics	Application	Examples
Diagonal Directional Arrow 	Square field Background green to correspond to accompanying sign White symbol	Direction to the location of fire-fighting equipment or utility; always used in conjunction with, and adjacent to, another symbol indicating the particular equipment or utility	
Child Care Center 	Square field Blue infant and hands White background	The identification and location of child care centers	On the door opening into child care centers At a fire department command or access point indicating presence and location of child care centers
Emergency Telephone 	Square field Red background White phone	The identification and location of fire service or emergency telephone system	
No Fire Fighting 	Red prohibition symbol Circular field White background Black truck within black octagonal outline	To be posted on, near, or on the approach to buildings where fire fighting is not to occur	Explosives bunkers, frangible buildings, or contaminated buildings
Self-Contained Breathing Apparatus (SCBA) 	Rectangular field White symbol Green background	To indicate the location of SCBA, breathing air connections, or refill location	For SCBA fill locations in high-rise buildings

Chapter 6 Symbols for Use in Architectural and Engineering Drawings and Insurance Diagrams

6.1* Introduction.

6.1.1 This chapter presents symbols that shall be used in drawings and diagrams.

6.1.2* Symbol Presentation.

6.1.2.1* Symbol Shapes. The shape of symbols shall be as illustrated in Sections 6.2 through 7.9.

6.1.2.2 Screened Lines. Screened lines in the chapter shall not be considered part of the symbol but shall be used to represent the piping, wiring, or mounting surface associated with the symbol.

6.1.2.3 Symbol Scale. All scales for symbols on any one drawing shall be the same relative size.

6.1.2.4* Symbol Orientation. Symbols shall be oriented to the walls, piping, electrical lines, and so forth, to which they are attached.

6.2 Symbols for Site Features.

6.2.1 Buildings.

6.2.1.1 The exterior walls of buildings shall be outlined in single thickness lines if other than fire rated and double thickness lines if fire rated.

6.2.1.2* The perimeter of canopies, loading docks, and other open-walled structures shall be shown by broken lines.

6.2.2 Railroad Tracks. Railroad tracks shall be shown by a single line with cross dashes, as shown in Figure 6.2.2.

6.2.3* Streets. Streets shall be shown.

6.2.4* Bodies of Water. Rivers, lakes, and so forth, shall be outlined.

6.2.5 Fences.

6.2.5.1 Fences shall be shown by lines with x's evenly spaced.

6.2.5.2* Gates shall be shown.

6.2.6 Property Lines. The notation given in Figure 6.2.6 shall indicate property lines.

6.2.7 Fire Department Access. The symbol for fire department access shall be as shown in Figure 6.2.7.

6.2.8 Other Site Features. For other fire protection site features, Section 7.2 shall be viewed.



FIGURE 6.2.2 Symbol for Railroad Tracks.

FIGURE 6.2.6 Notation Indicating Property Lines.



FIGURE 6.2.7 Symbol for Fire Department Access.

6.3 Symbols for Building Construction.

6.3.1* Types of Building Construction. Types of construction shall be shown narratively.

6.3.2* Height. Height shall be shown to indicate number of stories above ground, number of stories below ground, and height from grade to eaves.

6.3.3* Symbols for Walls and Parapets. Symbols for walls and parapets shall be as given in Table 6.3.3.

6.3.4 Symbols for Floor Openings, Wall Openings, Roof Openings, and Their Protection. Symbols for floor openings, wall openings, roof openings, and their protection shall be as given in Table 6.3.4.

6.3.5* Special Symbols for Cross-Sections. The symbols shown in Table 6.3.5 shall be used to indicate features of cross-sections. It is recognized that descriptive notes often are required.

6.3.6 Miscellaneous Features. A number of features related to fire protection that do not fall under 6.3.1 through 6.3.5 shall be as given in Table 6.3.6.

Table 6.3.3 Symbols for Walls and Parapets

Symbol	Description
	Wall — basic shape
	Smoke-rated wall
	1/2-hour fire-rated wall
	1/2-hour fire/smoke-rated wall
	3/4-hour fire-rated wall
	3/4-hour fire/smoke-rated wall
	1-hour fire-rated wall
	1-hour fire/smoke-rated wall
	2-hour fire-rated wall
	2-hour fire wall
	2-hour fire/smoke-rated wall
	3-hour fire-rated wall
	3-hour fire wall
	3-hour fire/smoke-rated wall
	4-hour fire-rated wall
	4-hour fire wall
	4-hour fire/smoke-rated wall
	Parapet — one cross for each 150 mm (6 in.) parapet that extends above roof (shown is plan view of symbol)

Table 6.3.4 Symbols for Floor Openings, Wall Openings, Roof Openings, and Their Protection and Life Safety Plans

Symbol	Description	Comments
	Opening in wall	
	Rated fire door in wall (less than 3 hours)	
	Fire door in wall (3-hour rated)	
	Elevator in combustible shaft	
	Elevator in noncombustible shaft	
	Open hoistway	
	Escalator	
	Stairs in combustible shaft	
	Stairs in fire-rated shaft	
	Stairs in open shaft	
	Skylight	
E: --	Egress component identifier	Specify egress component: EX# = Exit number HE = Horizontal exit EP = Exit passageway CP = Common path of travel PD = Public discharge RD = Room door ES = Escape
< --- >	Egress component capacity	Specify allowable number of persons through egress component (e.g., < 25 >)
<< --- >>	Governing component capacity	Specify maximum capacity of the egress path

(continues)

Table 6.3.4 Continued

Symbol	Description	Comments
	Travel distance	Left side: Distance to egress component Right side: Egress component identifier
	Occupancy capacity	Top: Specify capacity Middle: Specify area [square feet (square meters)] Bottom: Specify occupant load factor
	Fire door	
	Non-rated fire door	
	Non-rated smoke-resistant fire door	
	20-minute fire-rated fire door	
	20-minute fire-rated, smoke-resistant fire door	
	1/2-hour fire-rated fire door	
	1/2-hour fire-rated, smoke-resistant fire door	
	3/4-hour fire-rated fire door	
	3/4-hour fire-rated, smoke-resistant fire door	
	1-hour fire-rated fire door	

(continues)

Table 6.3.4 Continued

Symbol	Description	Comments
	1-hour fire-rated, smoke-resistant fire door	
	1 1/2-hour fire-rated fire door	
	1 1/2-hour fire-rated, smoke-resistant fire door	
	2-hour fire-rated fire door	
	2-hour fire-rated, smoke-resistant fire door	
	3-hour fire-rated fire door	
	3-hour fire-rated, smoke-resistant fire door	
	Exit	Wide, black, solid line
	Exit access	Wide, black, dashed line
	Exit discharge	Wide, black, short, dashed line

Table 6.3.5 Special Symbols for Cross-Sections

Symbol	Description	Comments
	Fire-resistive floor or roof	
	Wood-joisted floor or roof	
	Other floors or roofs (Steel deck on steel joists)	Note construction
	Floor/ceiling or roof/ceiling assembly	Details indicated, as necessary
	Floor on ground	
	Truss roof	Note construction

Table 6.3.6 Miscellaneous Features

Symbol	Description	Comments
	Boiler	
	Chimney	Describe height and construction
	Fire escape	
	Horizontal aboveground tank	Indicate type, dimensions, construction, capacity, pressurization, and content
	Vertical aboveground tank	Indicate type, dimensions, construction, capacity, pressurization, and content
	Belowground tank	Indicate type, dimensions, construction, capacity, pressurization, and content
	Class I, Division 1 or 0	Hatch patterns for electrically classified locations
	Class I, Division 1 or Zone 1	Hatch patterns for electrically classified locations
	Class I, Division 2 or Zone 2	Hatch patterns for electrically classified locations
	Designates the location of automated external defibrillators (AEDs) on plans	

Chapter 7 Symbols for Use in Water Supply, Extinguishing, and Sprinkler System Drawings and Insurance Diagrams

7.1* Introduction.

7.1.1 This chapter presents symbols that shall be used in drawings and diagrams.

7.1.2* Symbol Presentation.

7.1.2.1* Symbol Shapes. The shape of symbols shall be as illustrated in Sections 7.2 through 7.7.

7.1.2.2 Screened Lines. Screened lines in the chapter shall not be considered part of the symbol but shall be used to represent the piping, wiring, or mounting surface associated with the symbol.

7.1.2.3 Symbol Scale. All scales for symbols on any one drawing shall be the same relative size.

7.1.2.4* Symbol Orientation. Symbols shall be oriented to the walls, piping, electrical lines, and so forth, to which they are attached.

7.2* Water Supply and Distribution Symbols. Water supply and distribution symbols shall be as given in Table 7.2.

7.3 Reserved.

7.4 Symbols Related to Means of Egress. Symbols related to means of egress shall be as given in Table 7.4.

7.5 Indicating Appliances. Symbols for indicating appliances shall be as given in Table 7.5.

7.6* Symbols for Fire Extinguishing Systems.

7.6.1 Various Types of Fire Extinguishing Systems.

7.6.1.1 Water-Based Systems. Symbols for water-based systems shall be as given in Table 7.6.1.1.

7.6.1.2 Dry Chemical Systems. Symbols for dry chemical systems shall be as given in Table 7.6.1.2.

7.6.1.3 Systems Utilizing a Gaseous Medium. Symbols for systems utilizing a gaseous medium shall be as given in Table 7.6.1.3.

7.6.1.4 Supplementary Symbols. Supplementary symbols shall be as given in Table 7.6.1.4.

7.6.2 Symbols for Fire Sprinklers. Symbols for fire sprinklers shall be as given in Table 7.6.2.

7.6.2.1* For sprinklers shown in Table 7.6.2, the temperature rating of the sprinkler and other characteristics shall be shown via legends or noted on drawings where a limited number of an individual type of sprinkler is called for by the design.

7.6.3* Symbols for Piping, Valves, Control Devices, and Hangers. Symbols for piping, valves, control devices, and hangers shall be as given in Table 7.6.3.

7.7 Symbols for Portable Fire Extinguishers. Symbols for portable fire extinguishers shall be as given in Table 7.7.

7.8 Symbols for Fire-Fighting Equipment. Symbols for fire-fighting equipment shall be as given in Table 7.8.

7.9* Miscellaneous Symbols. Miscellaneous symbols shall be as given in Table 7.9.

Table 7.2 Water Supply and Distribution Symbols

Symbol	Description	Comments
	City or county public water main	Indicate pipe size and material
	Private fire line water main	Indicate pipe size and material
	Water main under building	Indicate pipe size and material
	Suction pipe	Indicate pipe size and material
	Thrust block	
	Riser	
	Wet riser	
	Dry riser	
	Preaction riser	
	Nitrogen-filled dry riser	
	Nitrogen-filled preaction riser	
	Pipe elbow up or down	Height on either side indicated by pipe height tags
	Pipe tee up or down	Height of crossed pipes indicated by pipe height tags
	Valves (general)	Basic shape; indicate valve size
	Valve in pit	Indicate valve size
	Post-indicator valve	Indicate valve size
	Key-operated valve	Indicate valve size

(continues)

Table 7.2 Continued

Symbol	Description	Comments
	OS&Y valve (outside screw and yoke, rising stem)	Indicate valve size
	Indicating butterfly valve	Indicate valve size
	Nonindicating valve (nonrising-stem valve)	Indicate valve size
	Check valve	Basic shape; indicate valve size, direction of flow
	Backflow preventer — double check type	Also referred to as a double check valve assembly
	Backflow preventer — reduced pressure zone (RPZ) type	
	Pressure-regulating valve	
	Pressure relief valve	
	Float valve	
	Meter	Indicate type
	Private hydrant, one hose outlet	Indicate size, type of thread, or connection
	Public hydrant, two hose outlets	Indicate size, type of thread, or connection
	Public hydrant, two hose outlets and pumper connection	Indicate size, type of thread, or connection
	Wall hydrant, two hose outlets	Indicate size, type of thread, or connection

(continues)

Table 7.2 Continued











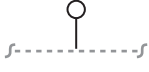
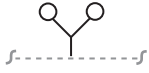

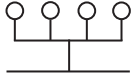
Symbol	Description	Comments
	Private housed hydrant, two hose outlets	Indicate size, type of thread, or connection
	Single fire department connection	Specify type, size, thread, and angle
	Siamese fire department connection	Specify type, size, and angle
	Wall flush 2 inlet fire department connection	Specify type, size, and connections
	Wall flush 3 inlet fire department connection	Specify type, size, and connections
	Wall flush 4 inlet fire department connection	Specify type, size, and connections
	Freestanding siamese fire department connection	Sidewalk or pit type; specify size
	Freestanding 3 inlet fire department connection	Specify type, size, and connections
	Freestanding 4 inlet fire department connection	Specify type, size, and connections
	Fire pump with driver	Specify driver type and rated capacity
	Freestanding test header	Freestanding; specify number and sizes of outlets
	Wall-mounted test header	Wall; specify number and sizes of outlets
	Screen/strainer	
	Riser air compressor	Specify size
	Tank air compressor	Specify size
	Tank nitrogen generator	Specify size

Table 7.4 Symbols Related to Means of Egress



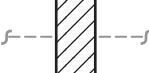



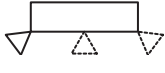

Symbol	Description	Comments
	Emergency light, battery-powered	Number of lamps on unit to be indicated; indicate whether light head(s) [lamp(s)] is remote from battery
	Illuminated exit sign, single face	Indicate direction of flow for the face
	Illuminated exit sign, double face	Indicate direction of flow for each face
	Combined battery-powered emergency light and illuminated exit sign	Number of lamps on unit to be indicated; indicate whether light head(s) [lamp(s)] is remote from battery; indicate direction of flow for the face
	Exit lighting	Exit lighting fixture, arrows, and exit face as indicated on drawings (mounting heights to be determined by job specifications) — from NECA NEIS 100, symbol 2.005
	Luminaire providing emergency illumination (filled in)	From NECA NEIS 100, symbol 2.300
	Directional sounder — exit marking audible appliance, wall mounted	Applied from NECA NEIS 100, symbol 9.109
	Directional sounder — exit marking audible appliance, ceiling mounted	Applied from NECA NEIS 100, symbol 9.110
	Directional exit indicating strip lighting appliance	Applied from NECA NEIS 100, symbol 2.002

Table 7.5 Symbols for Indicating Appliances

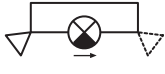

Symbol	Description	Comments
	Water motor alarm (water motor gong)	Shield optional, specify size
	Electric bell	Specify size

Table 7.6.1.1 Symbols for Water-Based Systems















Symbol	Description
	Wet charged system — automatically actuated
	Wet charged system — manually actuated
	Dry system — automatically actuated, air filled
	Dry system — manually actuated, air filled
	Dry system — automatically actuated, nitrogen filled
	Dry system — manually actuated, nitrogen filled
	Pre-action dry system — automatically actuated, air filled
	Pre-action dry system — manually actuated, air filled
	Pre-action dry system — automatically actuated, nitrogen filled
	Pre-action dry system — manually actuated, nitrogen filled
	Foam system — automatically actuated
	Foam system — manually actuated
	Water mist extinguishing system — automatically actuated
	Water mist extinguishing system — manually actuated

Table 7.6.1.2 Symbols for Dry Chemical Systems





Symbol	Description
	For liquid, gas, and electrical fires — automatically actuated
	For liquid, gas, and electrical fires — manually actuated
	For fires of all types (except metals) — automatically actuated
	For fires of all types (except metals) — manually actuated

Table 7.6.1.3 Symbols for Systems Utilizing a Gaseous Medium





Symbol	Description
	Carbon dioxide system — automatically actuated
	Carbon dioxide system — manually actuated
	Halon system or clean agent extinguishing system — automatically actuated
	Halon system or clean agent extinguishing system — manually actuated

Table 7.6.1.4 Supplementary Symbols





















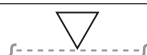













Symbol	Description
	Fully sprinklered space
	Partially sprinklered space
	Nonsprinklered space
	Water spray system

Table 7.6.2 Symbols for Fire Sprinklers

Symbol	Description	Comments
	Upright sprinkler	
	Pendent sprinkler	Note "DP" on drawing and/or in specifications where dry pendent sprinklers are employed
	Upright sprinkler; on sprig	
	Upright sprinkler on top of riser nipple	
	Upright sprinkler on sprig on top of riser nipple	
	Pendent sprinkler; on drop nipple	
	Sidewall sprinkler	
	Upright on sprig — extended coverage	'X' behind a head denotes extended coverage type
	Pendent drop — extended coverage	'X' behind a head denotes extended coverage type
	Upright on sprig — extended coverage with guard	'G' next to a head denotes head guard installed
	Pendent drop — extended coverage with guard	'G' next to a head denotes head guard installed
	Dry upright on sprig	
	Dry pendent drop	

(continues)

Table 7.6.2 Continued

Symbol	Description	Comments
	Dry upright on sprig — extended coverage	
	Dry pendent drop — extended coverage	
	Dry horizontal sidewall	
	Dry horizontal sidewall	Alternate symbol
	Dry horizontal sidewall — extended coverage	
	Dry horizontal sidewall — extended coverage	Alternate symbol
	Dry vertical sidewall sprinkler	
	Dry vertical sidewall sprinkler	Alternate symbol
	Attic upright sprinkler	
	Attic upright sprinkler	Alternate symbol
	Attic upright sprinkler (on sprig)	
	Attic upright sprinkler (on sprig)	Alternate symbol
	Attic back to back	
	Attic back to back	Alternate symbol
	Attic single directional	
	Attic single directional	Alternate symbol
	Attic hip single directional	
	Attic hip single directional	Alternate symbol

(continues)

Table 7.6.2 Continued

Symbol	Description	Comments
	Attic back to back (on sprig)	
	Attic back to back (on sprig)	Alternate symbol
	Attic single directional (on sprig)	
	Attic single directional (on sprig)	Alternate symbol
	Attic hip single directional (on sprig)	
	Attic hip single directional (on sprig)	Alternate symbol
	Vertical sidewall sprinkler	
	Vertical sidewall sprinkler	Alternate symbol
	Concealed space sprinkler	
	Concealed space sprinkler	Alternate symbol
	Concealed space sprinkler (on sprig)	
	Concealed space sprinkler (on sprig)	Alternate symbol
	Outside sprinkler	Specify type, orifice size; for example, open sprinkler (window or cornice)
	Open sprinkler on branch line	

(continues)

Table 7.6.2 Continued

Symbol	Description	Comments
	Open sprinkler on branch line with sprig	
	Open upright sprinkler	
	Open pendent sprinkler	
	Open upright sprinkler on sprig	
	Open pendent sprinkler on drop	
	Open directional spray nozzle	
	Open directional spray nozzle on sprig	
	Open directional spray nozzle on drop	
	Water spray nozzle	
	Window sprinklers	

Table 7.6.3 Symbols for Piping, Valves, Control Devices, and Hangers

Symbol	Description	Comments
	Sprinkler piping and branch line	Indicate pipe size
	Existing sprinkler piping and branch line	Indicate pipe size
	Demo sprinkler piping and branch line	Indicate pipe size
	Underground sprinkler supply piping	Indicate pipe size
	Pipe trace heater	See NECA 100, symbol 5.106
	Mechanical coupling	
	Pipe hanger	Diagonal stroke imposed on the pipe that the hanger supports
	Lateral brace	
	Longitudinal brace	
	Four-way brace	Only used to brace risers
	Vertical rise brace	Indicate pipe size
	Branch line cable restraint	Indicate pipe size
	Angle valve (angle hose valve)	Indicate size, type, and other required data
	Floor/zone control valve assembly	Specify size
	Check valve (general)	
	Riser check valve (general)	Specify size

(continues)

Table 7.6.3 Continued

Symbol	Description	Comments
	Alarm check valve	Specify size
	Dry pipe valve	Specify size
	Dry pipe valve with quick opening device (accelerator or exhauster)	Specify size and type
	Dry pipe valve — nitrogen charged	Specify size
	Dry pipe valve with quick opening device — nitrogen charged	Specify size
	Deluge valve	Specify size and type
	Preaction valve	Specify size and type
	Preaction valve — nitrogen charged	Specify size

Table 7.7 Symbols for Portable Fire Extinguishers









Symbol	Description	Comments
	Portable fire extinguisher	Basic shape
	Water extinguisher	
	Foam extinguisher	
	Dry chemical extinguisher for liquid, gas, or electrical fires	BC type
	Dry chemical extinguisher for fires of all types (except metals)	ABC type
	CO ₂ extinguisher	
	Halon or clean agent extinguisher	
	Extinguisher for metal fires	

Table 7.8 Symbols for Fire-Fighting Equipment





















Symbol	Description	Comments
	Fire-fighting equipment	Basic shape
	CO ₂ reel station	
	Dry chemical reel station	
	Fire hose valve connection	Specify thread size
	Foam reel station	
	Hose station, dry standpipe	
	Hose station, wet standpipe	
	Monitor nozzle, dry	Specify orifice size
	Monitor nozzle, charged	Specify orifice size

Table 7.9 Miscellaneous Symbols

Symbol	Description	Comments
	Agent storage container	Specify type of agent and mounting
	Agent storage container — foam	
	Agent storage container — Halon	
	Agent storage container — carbon dioxide	
	Agent storage container — clean agent	
	Agent storage container — dry chemical	
	Agent storage container — water mist	
	Agent storage container — wet chemical	
	Special spray nozzle	Specify type, orifice, size, other required data (shown here on pipe)
	Fusible link	Specify degrees
	Fusible link with electrothermal feature	Specify degrees

Chapter 8 Symbols for Use in Electronic Fire and Smoke Detection and Notification System Drawings and Insurance Diagrams

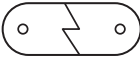
8.1* Introduction.

8.1.1 This chapter presents symbols that shall be used in drawings and diagrams.

8.1.2* Symbol Presentation.

8.1.2.1* **Symbol Shapes.** The shape of symbols shall be as illustrated in Sections 8.2 through 8.6.

8.1.2.2 **Screened Lines.** Screened lines in the chapter shall not be considered part of the symbol but shall be used to represent the piping, wiring, or mounting surface associated with the symbol.

8.1.2.3 **Symbol Scale.** All scales for symbols on any one drawing shall be the same relative size.

8.1.2.4* **Symbol Orientation.** Symbols shall be oriented to the walls, piping, electrical lines, and so forth, to which they are attached.

8.2 Symbols for Control Panels. Symbols for control panels shall be as given in Table 8.2.

Table 8.2 Symbols for Control Units (Panels)

Symbol	Description
	Basic shape
AMP	Amplifier rack
ARCM	Area of refuge emergency communication system — master unit
ARCR	Area of refuge emergency communication system — remote unit
ACU	Autonomous control unit
BATT	Battery cabinet
CRT	Cathode ray tube
HVAC	Control panel for heating (H), ventilation (V), air conditioning (AC), exhaust (E), stairwell pressurization (P)
DACR	Digital alarm communicator receiver
DACT	Digital alarm communicator transmitter
ESR	Elevator status/recall
ECCU	Emergency communications control unit















(continues)

Table 8.2 Continued

Symbol	Description
FAA	Fire alarm annunciator
FAC	Fire alarm communicator
FACP	Fire alarm control panel (legacy symbol for FACU)
FACU	Fire alarm control unit; include a 'D' subscript if it is a dedicated unit
FATC	Fire alarm terminal cabinet
TPR _n	Fire alarm transponder n = transponder number
FFI	Fire fighter interface
FSCP _{xx}	Fire suppression control panel (legacy symbol for FSCU) xx denotes suppression type
FSCU _{xx}	Fire suppression control unit xx denotes suppression type
GAP	Graphic annunciator panel
LCD	LCD annunciator/display
MFACU	Master fire alarm control unit
NAC _n	Notification circuit power booster, extender panel n = unit number
	Power panel
PRE	Pre-action system/control unit
PRN	Printer
PPCU	Protected premises control unit (local)
PP	Purge panel
RP	Relay panel
RSFACU	Releasing service fire alarm control unit
MIC	Remote voice evacuation microphone
EVAC _n	Remotely located evacuation amplifier cabinet
SAP	Sprinkler alarm panel
UPS	Uninterruptible power supply

















(continues)

Table 8.2 Continued

Symbol	Description
	Voice evacuation control unit
	Wireless control unit
Fire Suppression/Releasing Service Control Unit Types:	
	Aerosol
	Carbon dioxide
	Clean agent
	Deluge fire sprinkler
	Dry chemical
	Fire alarm control interface
	Fire pump controller
	Foam
	Halon
	Mass notification system interface
	Operating control unit
	Water mist
	Wet chemical

8.3* Symbols for Fire Alarms, Detection, and Related Equipment — Signal Initiating Devices and Activation Switches. Symbols for signal initiating devices and activation switches shall be as given in Table 8.3.

Table 8.3 Symbols for Signal Initiating Devices and Activation Switches

Symbol	Description
Abort Switch Types:	
	Abort switch — basic shape
	Abort switch
	Aerosol release abort station
	Clean agent
	Deluge fire sprinkler
	Dry chemical
	Foam
	Halon
	Manual releasing station
	Preaction
	Water mist
	Wet chemical
Addressable Modules:	
	Addressable input monitor module
	Addressable input/output module; # denotes number of inputs and outputs
	Addressable output control module
	Isolation module

(continues)

Table 8.3 Continued

Symbol	Description
Automatic Detection Type:	
	Automatic detection and supervisory devices — basic shape
Flame Detection Types:	
	Flame detector basic shape XX = detection type
	Combination ultraviolet/infrared
	Infrared detector
	Ultraviolet detector
	Visible radiation detector
Gas Detection Types:	
	Gas detector/sensor basic shape XX = gas type
	Carbon dioxide detector
	Carbon monoxide detector
	Hydrogen chloride detector
	Methane detector
Heat Detection Types:	
	Heat detector/sensor — XX = type basic shape
	Combination rate of rise/fixed temperature
	Fixed temperature
	Heat detector — line type
	Heat detector/sensor (thermal detection)



(continues)

Table 8.3 Continued















Symbol	Description
	Rate compensation
	Rate of rise only
Interface and Supervisory Devices:	
	End of line device — capacitor
	End of line device — diode
	End of line device — relay
	End of line device — resistor
	Flow detector/switch
	High temperature switch
	Level detector/switch
	Low temperature switch
	Main/reserve
	Maintenance/disconnect switch
	Non-addressable output relay
	Pressure detector/switch
	Solenoid valve
	Supervised solenoid valve
	Surge suppressor
	Temperature supervisory switch
	Transfer switch — automatic with handle
	Transfer switch — manual with handle
	Valve supervisory switch

(continues)





Table 8.3 Continued

Symbol	Description
	Valve with integral supervisory switch
	Water detector

Manual Fire Alarm Box Types:









	Manual station — basic shape
	Aerosol
	Carbon dioxide
	Clean agent
	Deluge fire sprinkler
	Drill key
	Dry chemical
	Fire alarm master box
	Foam
	Halon
	Preaction
	Pull station/fire alarm box
	Water mist
	Wet chemical

Smoke Detection/Sensor Types:

	Smoke detector/sensor — basic shape orientation not to be changed
	Air sampling
	In duct
	Ionization
	Photoelectric

(continues)

Table 8.3 Continued

Symbol	Description
	Relay base
	Smoke/heat detector/carbon monoxide detector
	Smoke/heat detector/sensor combination
	Smoke alarm (single station)
	Smoke detector/sensor — beam receiver
	Smoke detector/sensor — beam transmitter
	Smoke detector/sensor — XX = type
	Smoke detector/sensor for duct
	Sounder base

8.4 Notification Appliances.

8.4.1 Notification appliance subscripts shall be applied to symbols as required for clarification (*see Table 8.4.1*).

Table 8.4.1 Notification Appliance Subscripts

Subscript	Meaning
C	Ceiling mount
H	High audible setting
L	Low audible setting
MNS	Mass notification system
P	Pendent
RI	Remote indicator
SL	Signal light
nW	Wattage setting (<i>n</i> = speaker tap)
WP	Weatherproof
WG	Wire guard

8.4.2 Notification Appliances. Symbols for notification appliances shall be as given in Table 8.4.2.

Table 8.4.2 Symbols for Notification Appliances

Symbol	Description
	Audible appliance — basic shape
	Bell — single stroke
	Bell — trouble
	Bell — vibrating
	Ceiling mount indicator
	Chime
	Chime — electronic
	Combination horn/visible CD = candela rating/setting
	Combination speaker/visible W = wattage CD = candela rating/setting
	Gong
	Horn only
	Mini-horn
	Remote alarm indicating and test switch
	Remote indicator
	Rotating beacon

(continues)

Table 8.4.2 Continued

Symbol	Description
	Speaker only, ceiling mount — denote wattage tap
	Speaker only, wall mount — denote wattage tap
	Visible only (strobe) — ceiling mount CD = candela rating/setting
	Visible only (strobe) — wall mount CD = candela rating/setting

8.4.3 Emergency Communications Notification Appliances. Symbols for emergency communication appliances shall be as given in Table 8.4.3.

Table 8.4.3 Symbols for Emergency Communications Notification Appliances

Symbol	Description
	Combination speaker/visible — ceiling mount CD = candela rating/setting, W = wattage
	Combination speaker/visible — wall mount CD = candela rating/setting, W = wattage
	Emergency textual visible appliance
	Visible only (strobe) — ceiling mount CD = candela rating/setting
	Visible only (strobe) — wall mount CD = candela rating/setting









8.5 Related Equipment. Symbols for related equipment shall be as given in Table 8.5.

Table 8.5 Symbols for Related Equipment

Symbol	Description
	Air sampling detector piping
	Door closer
	Door holder
	End of line resistor

(continues)

Table 8.5 Continued

Symbol	Description
	Fire service or emergency phone station — accessible
	Fire service or emergency phone station — basic shape
	Fire service or emergency phone station — handset
	Fire service or emergency phone station — jack
	Floor Warden Station
	Integrated smoke sensor and door closer
	Junction box
	Sync adapter module (strobe synchronization)
	Watchman's tour station





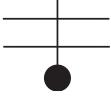
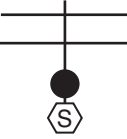
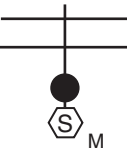

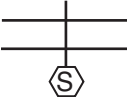

8.6 Symbols for Smoke/Pressurization Control. Symbols for smoke/pressurization controls shall be as given in Table 8.6.

Table 8.6 Symbols for Smoke/Pressurization Controls

Symbol	Description	Comments
	Dampers — barometric	
	Dampers — fire	
	Dampers — fire/ smoke	
	Dampers — motorized fire/ smoke	

(continues)

Table 8.6 Continued

Symbol	Description	Comments
	Dampers — smoke	
	Fans — duct	Arrow indicates direction of flow
	Fans — general	Arrow indicates direction of flow
	Fans — roof	Arrow indicates direction of flow
	Fans — wall	Arrow indicates direction of flow
	Hand (manual)/ off-automatic	
	Pressurized stairwell	Orient as required for base or head injection
	Purge controls — manual control	
	Ventilation openings	Orient as required for intake or exhaust

Chapter 9 Symbols for Use in Pre-Incident Planning Sketches

9.1 Introduction.

9.1.1* This chapter presents symbols that shall be used in pre-incident planning sketches.

9.1.2* **Symbol Shapes.** The symbol shapes shall be chosen for their ease of reproduction by either freehand drawing or with the use of templates.

9.2* **Access Features, Assessment Features, Ventilation Features, and Utility Shutoffs.** Symbols for access features, assessment features, ventilation features, and utility shutoffs shall be as given in Table 9.2.

9.3 **Detection/Extinguishing Equipment.** Symbols for detection/extinguishing equipment shall be as given in Table 9.3.

9.4 **Water Flow Control Valves and Water Sources.** Symbols for water flow control valves and water sources shall be as given in Table 9.4.

9.5 **Equipment Rooms.** Symbols for equipment rooms shall be as given in Table 9.5.

9.6* **Identification of Hazardous Materials.** NFPA 704 shall be permitted to be used to identify the location of hazardous materials within a structure.

Table 9.2 Symbols for Access Features, Assessment Features, Ventilation Features, and Utility Shutoffs

















Symbol	Description	Comments
	Access features, assessment features, ventilation features, and utility shutoffs	Basic shape
	Access feature — fire department access point	
	Access feature — fire department key box	
	Access feature — roof access	
	Assessment feature — fire alarm annunciator panel	
	Assessment feature — fire alarm reset panel	
	Assessment feature — fire alarm voice communication panel	
	Assessment feature — smoke control and pressurization panel	
	Assessment feature — sprinkler system water flow bell	
	Ventilation feature — skylight	
	Ventilation feature — smoke vent	
	Utility shutoff — electric	
	Utility shutoff — domestic water	
	Utility shutoff — gas	
	Specific variations — LP-Gas shutoff	
	Specific variations — natural gas shutoff	
	Specific variations — compressed natural gas shutoff	

Table 9.3 Symbols for Detection/Extinguishing Equipment















Symbol	Description	Comments
	Detection/ extinguishing equipment	Basic shape
	Duct detector	
	Heat detector	
	Smoke detector	
	Flow switch (water)	
	Manual station — pull station/fire alarm box	
	Tamper switch	
	Halon system	
	Dry chemical system	
	Carbon dioxide system	
	Wet chemical system	
	Foam system	
	Clean agent system	
	Beam smoke detector	

Table 9.4 Symbols for Water Flow Control Valves and Water Sources

Symbol	Description	Comments
○	Water flow control valves and water sources	Basic shape
○ PIV	Post-indicator valve	
○ RV	Riser valve	
○ ZV	Sprinkler zone valve	
○ SCV	Sectional control valve	
○ HC	Hose cabinet or connection	
○ WH	Wall hydrant	
○ TH	Test header (fire pump)	
○ TC	Inspector's test connection	
○ FH	Fire hydrant	
○ FDC	Fire department connection	
○ DS	Drafting site	
○ WT	Water tank	

Table 9.5 Symbols for Equipment Rooms

Symbol	Description	Comments
□	Equipment rooms	Basic shape
□ AC	Air-conditioning equipment room	AHUs = air-handling units
□ EE	Elevator equipment room	
□ EG	Emergency generator room	
□ FP	Fire pump room	
□ TE	Telephone equipment room	
□ BR	Boiler room	
□ ET	Electrical/transformer room	

Chapter 10 Symbology for Emergency Management Mapping

10.1 Damage Operational Symbols. Table 10.1 shall be used to cross-reference the damage operational symbols with their definitions.

10.2 Operations Symbology.

10.2.1 Organizations, services, capabilities, or resources available during or implemented due to an emergency management situation.

10.2.2 Table 10.2.2 shall be used to cross-reference the operations symbols with their definitions.

10.3 Incidents Symbology.

10.3.1 Table 10.3.2 shall be used to depict 8 themes and 42 features that symbolize a “cause of action” or a “source of disaster.”

10.3.2 Table 10.3.2 shall be used to cross-reference the incidents symbols with their definitions.

10.4 Natural Events Symbology.

10.4.1 A natural event shall be a phenomenon found in or created by naturally occurring conditions.

10.4.2 Table 10.4.2 shall be used to cross-reference the natural events symbols with their definitions.

10.5 Infrastructures Symbology.

10.5.1 Infrastructure shall be the basic facilities, services, and installations needed for the functioning of a community or society, such as transportation and communications systems, water and power lines, and public institutions, including schools, post offices, and prisons.

10.5.2 Table 10.5.2 shall be used to cross-reference the infrastructures symbols with their definitions.

Table 10.1 Damage Operational Symbology Reference











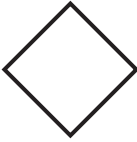
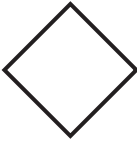
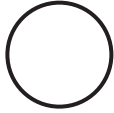

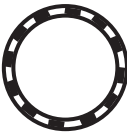







Symbol Types and Terms	Symbols	Definitions
Incident (No levels) (violet)		Not applicable
Natural Event (No levels) (black)		Not applicable
Operation (Level 1) (green)		Fully operational/open
Operation (Level 2) (blue)		Operational, but filled to capacity or otherwise closed
Operation (Level 3) (orange)		Operational, but partially damaged or partially incapacitated
Operation (Level 4) (red)		Destroyed or totally incapacitated
Infrastructure (Level 1) (green)		Fully operational/open
Infrastructure (Level 2) (blue)		Operational, but filled to capacity or otherwise closed
Infrastructure (Level 3) (orange)		Operational, but partially damaged or partially incapacitated
Infrastructure (Level 4) (red)		Destroyed or totally incapacitated

Table 10.2.2 Operations Symbology Reference

Symbol Types and Terms	Symbols	Keystroke	Definitions
Operations Background Symbol (Background)		!	The background fill shape for the Operations symbol, Level 1
Operations Frame Symbol (Frame)		#	The frame shape for the Operations symbol, Level 1
Emergency Medical Operation (Theme)		A	Urgent and unexpected medicinal treatment and/or transport during serious situations that require immediate action ¹
Ambulance (Emergency Medical Feature)		B	A vehicle for taking sick or wounded people to and from a hospital
EMT Station Locations (Emergency Medical Feature)		C	The locus of an emergency medical team
Medical Evacuation Helicopter Station (Emergency Medical Feature)		D	The locus of an emergency helicopter landing pad, utilized to transport severely injured persons
Health Department Facility (Emergency Medical Feature)		E	The locus of a facility operated by a public institution that is dedicated to promotion of health and prevention of disease at the community, county, state, or national level ²
Hospital (Emergency Medical Feature)		F	The locus of an institution where the sick or injured are given medical or surgical care
Hospital Ship (Emergency Medical Feature)		G	The locus of a ship where the sick or injured are given medical or surgical care
Medical Facilities Outpatient (Emergency Medical Feature)		H	The locus of a facility providing medical treatment to patients whose sickness or injury does not require hospitalization
Morgue (Emergency Medical Feature)		I	The locus of a place where the bodies of persons found dead are kept until identified and claimed by relatives or released for burial ³
Pharmacies (Emergency Medical Feature)		J	The locus of a place where medicines are compounded or dispensed ³
Triage (Emergency Medical Feature)		K	The locus of a place where sorting and allocation of treatment to patients (especially victims of war or disaster) are performed according to a system of priorities designed to maximize the number of survivors ³















(continues)

Table 10.2.2 Continued

Symbol Types and Terms	Symbols	Keystroke	Definitions
Emergency Operation (Theme)		L	Those actions taken during the emergency period to protect life and property, care for the people affected, and temporarily restore essential community services ⁴
Emergency Collection/Evacuation Point (Emergency Operation Feature)		M	A designated place where displaced persons or victims of war or disaster are assembled and/or evacuated from
Emergency Incident Command Center (Emergency Operation Feature)		N	The physical location from which an incident commander manages an incident ⁵
Emergency Operations Center (Emergency Operation Feature)		O	The physical location where an organization comes together during an emergency to coordinate response and recovery actions and resources and make management decisions ⁶
Emergency Public Information Center (Emergency Operation Feature)		P	No definition
Emergency Public Service Center (Emergency Operation Feature)		Q	No definition
Emergency Shelters (Emergency Operation Feature)		R	The locus of a designated emergency/relief shelter
Emergency Staging Areas (Emergency Operation Feature)		S	A designated place where emergency response forces, equipment, and supplies are assembled prior to engagement in operations
Emergency Teams (Emergency Operation Feature)		T	The locus of an emergency response team
Emergency Water Distribution Center (Emergency Operation Feature)		U	A place where potable water is distributed to displaced persons or victims of war or disaster
Emergency Food Distribution Centers (Emergency Operation Feature)		V	A place where food is distributed to displaced persons or victims of war or disaster
Fire Suppression Operation (Theme)		W	The extinguishing of a burning (and flaming) object by means of applying an agent, such as water ⁷

(continues)

Table 10.2.2 *Continued*

Symbol Types and Terms	Symbols	Keystroke	Definitions
Fire Hydrant (Fire Suppression Feature)		X	A discharge pipe with a valve and spout from which water can be drawn from a water main in sufficient volume and at sufficient pressure for fire-fighting purposes ⁸
Other Water Supply Location (Fire Suppression Feature)		Y	Any source of water other than a fire hydrant that is sufficient for the purpose of fire fighting
Fire Station (Fire Suppression Feature)		Z	A facility housing fire-fighting equipment and/or personnel
Law Enforcement Operation (Theme)		a	Act of ensuring obedience to the laws ⁹
ATF (Law Enforcement Feature)		b	A locus of U.S. Bureau of Alcohol, Tobacco, and Firearms facilities, equipment, or personnel
Border Patrol (Law Enforcement Feature)		c	A locus of U.S. Border Patrol facilities, equipment, or personnel
Customs Service (Law Enforcement Feature)		d	A locus of U.S. Customs Service facilities, equipment, or personnel
DEA (Law Enforcement Feature)		e	A locus of U.S. Drug Enforcement Administration facilities, equipment, or personnel
DOJ (Law Enforcement Feature)		f	A locus of U.S. Department of Justice facilities, equipment, or personnel
FBI (Law Enforcement Feature)		g	A locus of Federal Bureau of Investigation facilities, equipment, or personnel
Police (Law Enforcement Feature)		h	A locus of federal, state, or local police facilities, equipment, or personnel
Prison (Law Enforcement Feature)		i	A facility for the confinement of persons convicted of serious crimes ³
Secret Service (Law Enforcement Feature)		j	A locus of U.S. Secret Service facilities, equipment, or personnel
TSA (Law Enforcement Feature)		k	A locus of U.S. Transportation Security Administration facilities, equipment, or personnel











(continues)

Table 10.2.2 *Continued*

Symbol Types and Terms	Symbols	Keystroke	Definitions
U.S. Coast Guard (Law Enforcement Feature)		l	A locus of U.S. Coast Guard facilities, equipment, or personnel
U.S. Marshals Service (Law Enforcement Feature)		m	A locus of U.S. Marshals Service facilities, equipment, or personnel
Sensor Operation (Theme)		n	A device that receives and responds to a signal or stimulus ⁹
Biological Sensor (Sensor Operation Feature)		o	A device designed to respond to the presence of one or more biological substances and to transmit a resulting impulse ¹⁰
Chemical Sensor (Sensor Operation Feature)		p	A device designed to respond to the presence of one or more chemicals and to transmit a resulting impulse ¹⁰
Intrusion Sensor (Sensor Operation Feature)		q	A device designed to respond to physical penetration of, or attempts to physically penetrate, a protected area or spatial volume and to transmit a resulting impulse ¹⁰
Nuclear Sensor (Sensor Operation Feature)		r	A device designed to respond to one or more decay product(s) of one or more radioactive nuclides and to transmit a resulting impulse ¹¹
Radiological Sensor (Sensor Operation Feature)		s	A device designed to respond to one or more decay product(s) of one or more radioactive nuclides and to transmit a resulting impulse ¹¹



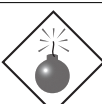









¹Source: www.dictionary.com; combined definition of *emergency* and *medical*.²Source: Based on the APHA public health mission statement.³Source: Merriam-Webster Online.⁴Source: Adapted from San Diego State University Emergency Plan glossary, <http://bfa.sdsu.edu/emergencyplan/glossary.htm>.⁵Source: Commonwealth of Virginia ICS, www.vdvp.state.va.us/components.htm.⁶Source: EMS web site, www.emsresponder.com.⁷Source: Adapted from www.firewise.org glossary of terms.⁸Source: Adapted from Merriam-Webster Online definition of *hydrant*.⁹Source: www.dictionary.com.¹⁰Source: Adapted from Merriam-Webster Online definition of *sensor*.¹¹Source: Adapted from Merriam-Webster Online definition of *sensor* and knowledge of the process, detection, and measurement of radioactivity.

Table 10.3.2 Incidents Symbology Reference

Symbol Types and Terms	Symbols	Keystroke	Definitions
Incidents Stage 01 Background Symbol (Background)		!	The background fill shape for the Incidents symbol, Level 1
Incidents Stage 01 Frame Symbol (Frame)		#	The frame shape for the Incidents symbol, Level 1
Civil Disturbance Incident (Theme)		A	Human activities resulting in the disrupting of services or requiring varying levels of support, law enforcement, or attention
Civil Demonstrations (Civil Disturbance Feature)		B	A public display of group feelings toward a person or cause ¹
Civil Displaced Population (Civil Disturbance Feature)		C	Persons or groups of people who have been forced or obliged to flee or to leave their homes or places of habitual residence, in particular as a result of or in order to avoid the effects of armed conflict, violations of human rights, or natural or human-made disasters ²
Civil Rioting (Civil Disturbance Feature)		D	A public disturbance involving (1) an act or acts of violence by one or more persons part of an assemblage of three or more persons, which act or acts shall constitute a clear and present danger of, or shall result in, damage or injury to the property of any other person or to the person of any other individual, or (2) a threat or threats of the commission of an act or acts of violence by one or more persons part of an assemblage of three or more persons having, individually or collectively, the ability of immediate execution of such threat or threats, where the performance of the threatened act or acts of violence would constitute a clear and present danger of, or would result in, damage or injury to the property of any other person or to the person of any other individual ³
Criminal Activity Incident (Theme)		E	An unlawful pursuit or action in which an individual participates ⁴
Bomb Threat (Criminal Activity Feature)		F	A warning of the possible presence of a bomb or expression of the intention to detonate a bomb
Bomb (Criminal Activity Feature)		G	An explosive device fused to detonate under specific conditions ⁵
Bomb Explosion (Criminal Activity Feature)		H	A violent outburst resulting from detonation of a chemical or nuclear explosive or from the loss of a high pressure vessel's integrity











(continues)

Table 10.3.2 *Continued*

Symbol Types and Terms	Symbols	Keystroke	Definitions
Looting (Criminal Activity Feature)		I	Burglary committed within an affected area during an emergency ⁶
Poisoning (Criminal Activity Feature)		J	Use of a poisonous substance to injure or kill ¹
Shooting (Criminal Activity Feature)		K	Use of a firearm to kill or injure or to damage property ¹
Fire Incident (Theme)		L	The destructive act of something burning, caused by electrical or technological malfunction, lightning, arson, human error, or human negligence
Hot Spot (Fire Incident Feature)		P	An area of intensified fire activity and increased heat or a particularly active part of a fire
Non-Residential Fire (Fire Incident Feature)		Q	A fire that originates at or affects a non-residential or commercial facility, resulting in partial damage or total destruction of the structure and/or bodily injury, smoke inhalation, or death
Origin (Fire Incident Feature)		R	Location of where the fire started ⁷
Residential Fire (Fire Incident Feature)		S	A fire affecting a home or housing complex, resulting in partial or total destruction of the structure and/or bodily injury, smoke inhalation, or death
School Fire (Fire Incident Feature)		T	A fire that originates at or affects an educational facility, resulting in partial or total destruction of the structure and/or bodily injury, smoke inhalation, or death
Smoke (Fire Incident Feature)		U	The visible products of combustion rising above the fire ⁸
Special Needs Fire (Fire Incident Feature)		V	A fire that affects special treatment facilities, such as nursing homes or assisted living centers, resulting in partial or total destruction of the structure and/or bodily injury, smoke inhalation, or death
Wild Fire (Fire Incident Feature)		W	An uncontrolled fire in a wooded area ⁹
Hazardous Incident (Theme)		X	See footnote. ¹⁰













(continues)

Table 10.3.2 *Continued*

Symbol Types and Terms	Symbols	Keystroke	Definitions
Chemical Agent (Hazardous Incident Feature)		Y	A chemical substance that is intended for use in military operations to kill, resulting in psychological disorientation, serious injury, incapacitation, or death ¹¹
Corrosive Material (Hazardous Incident Feature)		Z	Uncontrolled or potentially dangerous presence of a liquid or solid that causes full thickness destruction of human skin at the site of contact within a specified period of time
Dangerous When Wet (Hazardous Incident Feature)		a	Uncontrolled or potentially dangerous presence of a material that, by contact with water, is liable to become spontaneously flammable or to give off flammable or toxic gas at a rate greater than 1 L/hr per kilogram of the material per hour (0.48 qt/hr/lb)
Explosive (Hazardous Incident Feature)		b	Uncontrolled or potentially dangerous presence of any substance or article, including a device that is designed to function by explosion (i.e., an extremely rapid release of gas and heat) or that, by chemical reaction within itself, is able to function in a similar manner even if not designed to function by explosion
Flammable Gas (Hazardous Incident Feature)		c	Uncontrolled or potentially dangerous presence of any material that is a gas at 20°C (68°F) or less and 101.3 kPa (14.7 psia) of pressure [a material that has a boiling point of 20°C (68°F) or less at 101.3 kPa (14.7 psia)], that is ignitable at 101.3 kPa (14.7 psia) when in a mixture of 13 percent or less by volume with air, or that has a flammable range at 101.3 kPa (14.7 psia) with air of at least 12 percent regardless of the lower limit
Flammable Liquid (Hazardous Incident Feature)		d	Uncontrolled or potentially dangerous presence of a liquid having a flash point of not more than 60.5°C (141°F)
Flammable Solid (Hazardous Incident Feature)		e	Uncontrolled or potentially dangerous presence of desensitized explosives that when dry are explosives of Class 1, which are wetted with sufficient water, alcohol, or plasticizer to suppress explosive properties
Nonflammable Gas (Hazardous Incident Feature)		f	Uncontrolled or potentially dangerous presence of any material (or mixture) that exerts in the packaging an absolute pressure of 280 kPa (40.6 psia) or greater at 20°C (68°F) and is not classified as a flammable gas
Organic Peroxides (Hazardous Incident Feature)		g	No definition
Oxidizers (Hazardous Incident Feature)		h	Uncontrolled or potentially dangerous presence of a material that can, generally by yielding oxygen, cause or enhance the combustion of other materials
Radioactive Material (Hazardous Incident Feature)		i	Uncontrolled or potentially dangerous presence of any material having a specific activity greater than 70 Bq/g (17 µCi/oz)





(continues)

Table 10.3.2 *Continued*

Symbol Types and Terms	Symbols	Keystroke	Definitions
Spontaneously Combustible (Hazardous Incident Feature)		j	Uncontrolled or potentially dangerous presence of a liquid or solid that, even in small quantities and without an external ignition source, can ignite within 5 minutes after coming in contact with air or a material that, when in contact with air and without an energy supply, is liable to self-heat
Toxic Gas (Hazardous Incident Feature)		k	Uncontrolled or potentially dangerous presence of a gas that presents a hazard to human health
Toxic and Infectious (Hazardous Incident Feature)		l	Uncontrolled or potentially dangerous presence of a poisonous substance that is a specific product of the metabolic activities of a living organism and is usually very unstable and can easily be transferred between organisms
Unexploded Ordnance (Hazardous Incident Feature)		m	Uncontrolled or potentially dangerous presence of an unexploded weapon or ammunition
Air Incident (Theme)		n	An event involving aircraft resulting in damage, bodily injury, death, or the disruption of transportation service
Air Accident (Air Incident Feature)		o	A sudden, unexpected event involving aircraft resulting in fuselage damage, bodily injury, death, and/or the disruption of transportation service, prompting emergency landing procedures or uncontrolled impact with the ground
Air Hijacking (Air Incident Feature)		p	The unexpected, unlawful, and forceful seizure of control aboard an aircraft by an individual or group of individuals resulting in passenger and crew endangerment, injury or death, and/or the redirection of flight destination ¹²
Marine Incident (Theme)		q	An event involving a boat or ship and resulting in damage, bodily injury, death, or the disruption of transportation service
Marine Accident (Marine Incident Feature)		r	A sudden, unexpected event involving a boat or ship and resulting in vessel submerging, damage, bodily injury, death, and/or the disruption of transportation service
Marine Hijacking (Marine Incident Feature)		s	The unexpected, unlawful, and forceful seizure of control aboard a boat or ship by an individual or group of individuals resulting in passenger and crew endangerment, injury or death, and/or the redirection of destination ¹²
Rail Incident (Theme)		t	An event involving a train and resulting in damage, bodily injury, death, or the disruption of transportation service
Rail Accident (Rail Incident Feature)		u	A sudden, unexpected event involving a wheeled or tracked vehicle resulting in derailment, damage, bodily injury, death, and/or the disruption of transportation service

(continues)











Table 10.3.2 *Continued*

Symbol Types and Terms	Symbols	Keystroke	Definitions
Rail Hijacking (Rail Incident Feature)		v	The unexpected, unlawful, and forceful seizure of control aboard a wheeled or tracked vehicle by an individual or group of individuals resulting in passenger and crew endangerment, injury or death, and/or the redirection of destination ¹²
Vehicle Incident (Theme)		w	An event involving a wheeled or tracked vehicle and resulting in damage, bodily injury, death, or the disruption of transportation service
Vehicle Accident (Vehicle Incident Feature)		x	A sudden, unexpected event involving a vehicle and resulting in damage, bodily injury, death, and/or the disruption of transportation service
Vehicle Hijacking (Vehicle Incident Feature)		y	The unexpected, unlawful, and forceful seizure of control aboard a vehicle by an individual or group of individuals resulting in passenger and crew endangerment, injury or death, and/or the redirection of destination ¹²

Notes:











¹Source: Merriam-Webster Online Dictionary.²Source: United Nations *Guiding Principles on Internally Displaced Persons*, 1998.³Source: 18 USC Section 2102.⁴Source: www.dictionary.com; combined definitions of *criminal* and *activity*.⁵Source: International military definition.⁶Source: <http://peace-officers.com> glossary.⁷Source: U.S. Department of Agriculture, Forest Service, www.fs.fed.us.⁸Source: www.firewise.org⁹Source: www.realdictionary.com.¹⁰ All the proposed definitions for *hazardous incident* are from the Office of Hazardous Materials Safety, Hazmat Regulations and Interpretations.¹¹Source: Adapted from NATO definition, www.nato.int/docu/stanag/aap006/aap6.htm.¹²Source: www.dictionary.com, definition of *hijack*.

Table 10.4.2 Natural Events Symbolgy Reference

Symbol Types and Terms	Symbols	Keystroke	Definition
Natural Events Stage 01 Background Symbol (Background)		!	The background fill shape for the Natural Events symbol, Level 1
Natural Events Stage 01 Frame Symbol (Frame)		#	The frame shape for the Natural Events symbol, Level 1
Geologic (Theme)	Reserved		
Aftershock (Geologic Feature)		A	An earthquake that follows a larger earthquake and originates at or near the latter's focus ¹
Avalanche (Geologic Feature)		B	A large mass of snow, ice, soil, or rock, or mixtures of these materials, falling, sliding, or flowing very rapidly under the force of gravity ¹
Earthquake Epicenter (Geologic Feature)		C	The point on the earth's surface directly above the focus of an earthquake ¹
Landslide (Geologic Feature)		D	A general term for a wide variety of processes and landforms involving the down slope movement under the force of gravity of masses of soil and rock material ¹
Subsidence (Geologic Feature)		E	Sinking or downward settling of the Earth's surface ¹
Volcanic Eruption (Geologic Feature)		F	The ejection of volcanic materials (lava, pyroclasts, and volcanic gases) from a vent or fissure in the Earth's crust ¹
Volcanic Threat (Geologic Feature)		G	A vent or fissure in the Earth's crust where volcanic eruption is believed to be imminent ²
Hydro-Meteorologic (Theme)	Reserved		
Drizzle (Hydro-Meteorologic Feature)		H	Sometimes called <i>mist</i> , very small, numerous, and uniformly dispersed water droplets that appear to float while following air currents and that, unlike fog droplets, fall to the ground
Drought (Hydro-Meteorologic Feature)		I	A period of abnormally dry weather sufficiently prolonged for the lack of water to cause a serious hydrologic imbalance across the affected area. Drought severity depends upon the degree of moisture deficiency, the duration, and (to a lesser extent) the size of the affected area. In general, the term should be reserved for periods of moisture deficiency that are relatively extensive in both space and time.





(continues)

Table 10.4.2 *Continued*

Symbol Types and Terms	Symbols	Keystroke	Definition
Flood (Hydro-Meteorologic Feature)		J	A relatively high stream flow that overtops the stream banks in any part of its course, covering land that is not normally under water ¹ ; a condition that occurs when water overflows the natural or artificial confines of a stream or other body of water, or accumulates by drainage over low-lying areas
Fog (Hydro-Meteorologic Feature)		K	A visible aggregate of minute water droplets suspended in the atmosphere near the Earth's surface [According to international definition, fog reduces visibility to less than 1 km (5/8 mi). Fog differs from clouds only in that the base of the fog is at the Earth's surface, while clouds are above the surface.]
Hail (Hydro-Meteorologic Feature)		L	Precipitation in the form of circular or irregular-shaped lumps of ice ³
Inversion (Hydro-Meteorologic Feature)		M	A departure from the standard decrease or increase with altitude of value of an atmosphere property; almost always used to mean temperature inversion
Rain (Hydro-Meteorologic Feature)		N	Precipitation in the form of liquid water drops that have diameters greater than 0.5 mm (0.2 in.)
Sand Dust Storm (Hydro-Meteorologic Feature)		O	A strong wind carrying sand through the air, the diameter of most of the particles ranging from 0.08 mm to 1 mm (0 to 0.04 in.); in contrast to a dust storm, sand particles mostly confined to the lowest 0.6 m (2 ft) and rarely rising more than 15.2 m (50 ft) above the ground
Snow (Hydro-Meteorologic Feature)		P	Precipitation composed of white or translucent ice crystals, chiefly of complex branched hexagonal form and often agglomerated into snowflakes
Thunderstorm (Hydro-Meteorologic Feature)		Q	A consequence of atmospheric instability that constitutes an overturning of layers in order to achieve a more stable atmosphere; generally produces lightning, thunder, strong gusts of wind, heavy rain, and sometimes hail
Tornado (Hydro-Meteorologic Feature)		R	A violently rotating column, or funnel, of air in contact with the ground and extending from the base of a thunderstorm ³
Tropical Cyclone (Hydro-Meteorologic Feature)		S	The general term for a cyclone that originates over the tropical oceans
Tsunami (Hydro-Meteorologic Feature)		T	A great sea wave produced by an earthquake or volcanic eruption, characterized by high speed of propagation, long wavelength, long period, and low observable amplitude on the open ocean ¹ ; can reach enormous dimensions and has sufficient energy to travel across entire oceans; no connection with tides, as can be inferred from the commonly used term <i>tidal wave</i>
Infestation (Theme)	Reserved		

(continues)















Table 10.4.2 *Continued*

Symbol Types and Terms	Symbols	Keystroke	Definition
Bird Infestation (Infestation Feature)		U	A harassing or troublesome invasion of birds ⁴
Insect Infestation (Infestation Feature)		V	A harassing or troublesome invasion of insects
Microbial Infestation (Infestation Feature)		W	A harassing or troublesome invasion of microbes
Reptile Infestation (Infestation Feature)		X	A harassing or troublesome invasion of reptiles
Rodent Infestation (Infestation Feature)		Y	A harassing or troublesome invasion of rodents

Notes:







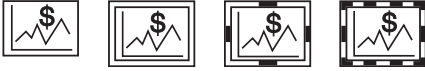

¹Source: *Dictionary of Geological Terms*, 3rd edition.²Source: Logical extension of *volcanic eruption*.³Source: Adapted from National Weather Service glossary, www.nws.noaa.gov/glossary.htm.⁴Source: Derived from the definition of *infestation* in FactMonster.com dictionary.

Table 10.5.2 Infrastructure Symbology Reference

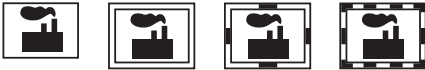
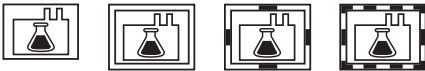
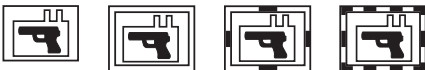
Symbol Types and Terms	Symbols	Keystroke	Definitions
Infrastructures Background Symbol (Background)		!	The background fill shape for the Infrastructures symbol, Level 1
Infrastructures Frame Symbol (Frame)		#	The frame shape for the Infrastructures symbol, Level 1
Agriculture and Food Infrastructure (Theme)		\$	Production and retail services of foodstuffs
Agricultural Laboratory (Agriculture and Food Feature)		%	Facilities used for scientific research in farming
Animal Feedlot (Agriculture and Food Feature)		&	Area designated for feeding livestock
Commercial Food Distribution Center (Agriculture and Food Feature)		(Facility used for the disbursement of marketable foodstuffs
Farm/Ranch (Agriculture and Food Feature)	)	A piece of land on which crops or animals are raised
Food Production Center (Agriculture and Food Feature)		*	The locus where foodstuffs are produced
Food Retail (Agriculture and Food Feature)		+	Facility where foodstuffs are sold for a profit
Grain Storage (Agriculture and Food Feature)		'	Facility used for the housing of cereal seeds such as corn, wheat, or barley
Banking, Finance, and Insurance Infrastructure (Theme)		-	The management of money and other assets and their protection ¹
ATM (Banking, Finance, and Insurance Feature)		.	An unattended machine commonly located at a bank's exterior that dispenses money when a personal coded card is inserted ²
Bank (Banking, Finance, and Insurance Feature)		/	A business establishment in which money is kept for saving for commercial purposes or is invested, supplied for loans, or exchanged ¹
Bullion Storage (Banking, Finance, and Insurance Feature)		0	A facility used to deposit and warehouse gold or silver bars or ingots ³
Federal Reserve Bank (Banking, Finance, and Insurance Feature)		1	One of twelve regional banks that monitor and act as depositories for banks in their region ²

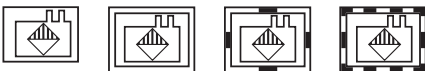



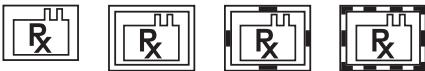

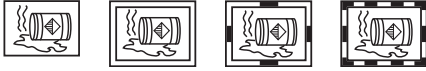

(continues)

Table 10.5.2 Continued

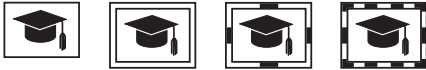
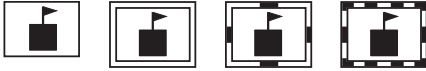
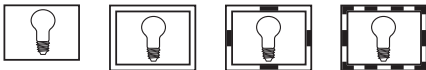
Symbol Types and Terms	Symbols	Keystroke	Definitions
Financial Exchange (Banking, Finance, and Insurance Feature)		2	A marketplace in which shares, options, and futures on stocks, bonds, commodities, and indexes are traded ⁴
Financial Service Other (Banking, Finance, and Insurance Feature)		3	A business establishment, other than a bank, for the provision of financial or monetary-related products and services; a location that deals with money management business
Commercial Infrastructure (Theme)		4	The locus of where a business enterprise is undertaken ²
Chemical Plant (Commercial Infrastructure Feature)		5	An industrial site where chemical substances and/or compounds are produced ²
Firearm Manufacturer (Commercial Infrastructure Feature)		6	A location where hand weapons of explosive force when shot are mass produced ⁵
Firearm Retailer (Commercial Infrastructure Feature)		7	A location where hand weapons of explosive force when shot are sold ⁶
Hazardous Material Production (Commercial Infrastructure Feature)		8	The locus of where hazardous chemicals and/or substances are produced and stored under regulated conditions
Hazardous Material Storage (Commercial Infrastructure Feature)		9	A storing location for a substance or combination of substances that, because of quantity, concentration, or physical, chemical, radiological, explosive, or infectious characteristics, poses a potential danger to humans and/or the environment ⁷
Industrial Site (Commercial Infrastructure Feature)		:	The locus of an industrial facility or facilities used for the commercial production and selling of manufactured goods ¹
Landfill (Commercial Infrastructure Feature)		;	An area of land or an excavation in which wastes are placed for permanent disposal, and which is not a land application unit, surface impoundment, injection well, or waste pile ⁸
Pharmaceutical Manufacturer (Commercial Infrastructure Feature)		=	The location where medicinal drugs are mass produced ⁹

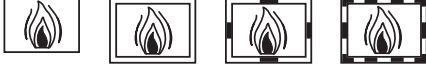
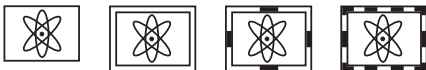

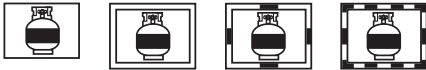









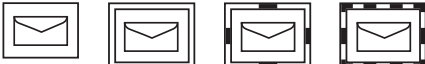
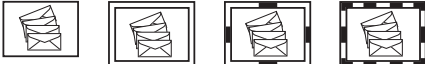

(continues)

Table 10.5.2 *Continued*

Symbol Types and Terms	Symbols	Keystroke	Definitions
Superfund Site National Priorities List (Commercial Infrastructure Feature)		?	A location in the United States that has been contaminated by hazardous waste and identified by the Environmental Protection Agency as a candidate for cleanup because it poses a risk to human health and/or the environment ¹⁰
Toxic Release Inventory (Commercial Infrastructure Feature)		@	The location according to a publicly available database of chemical and other toxic waste releases ¹⁰
Educational Facilities Infrastructure (Theme)		A	A building or collection of buildings or places in which knowledge is provided ¹¹
College/University (Educational Facilities Feature)		B	An institution of higher learning offering courses of studies leading to bachelor's, master's, or doctoral degrees ¹²
School (Educational Facilities Feature)		C	A facility for the primary and secondary education of children ¹³
Energy Facilities Infrastructure (Theme)		D	A building or collection of buildings and/or places that generates and provides electrical power
Generation Station (Energy Facilities Feature)		E	A facility equipped with special equipment used for the production of heat or electricity ¹⁴
Natural Gas Facility (Energy Facilities Feature)		F	A location equipped with special equipment used to generate natural gas power
Nuclear Facility (Energy Facilities Feature)		G	A location equipped with special equipment used to generate nuclear power
Petroleum Facility (Energy Facilities Feature)		H	A building or place that provides and distributes petroleum gas
Propane Facility (Energy Facilities Feature)		I	A building or place that provides and distributes propane gas
Government Site Infrastructure (Theme)		J	The locus of where executive, legislative, and/or judicial activities take place in the service of the government
Military Infrastructure (Theme)		K	Refers collectively to the four major branches of the United States' armed forces as associated with armed services as contrasted with civilians

(continues)

Table 10.5.2 Continued

Symbol Types and Terms	Symbols	Keystroke	Definitions
Military Armory (Military Feature)		L	A military structure where arms and ammunition and other military equipment are manufactured and stored, and also where training is given in the use of arms ²
Military Base (Military Feature)		M	The locus of where military personnel, weapons, and supplies are located and also where attacks and other operations are coordinated and launched
Postal Service Infrastructure (Theme)		N	The system whereby letters and other parcels are transmitted and delivered via the post office
Postal Distribution Center (Postal Feature)		O	A U.S. Postal Service (USPS) facility where mail is sorted and routed
Post Office (Postal Feature)		P	A USPS facility that directly delivers postal services to the public
Public Venue Infrastructure (Theme)		Q	An unrestricted place or places and events for a large gathering of people ¹
Church (Public Venues Feature)		R	A building for public and especially Christian worship ¹³
Enclosed Facility (Public Venues Feature)		S	A roofed facility with walls
Mosque (Public Venues Feature)		T	A building used for public worship by Muslims ¹³
Open Facility (Public Venues Feature)		U	An open-air facility with or without walls, for example, a stadium or a parking lot
Recreational Area (Public Venues Feature)		V	A place dedicated to the refreshment of strength and spirits after work ¹³
Religious Institution (Public Venues Feature)		W	Any place of worship where religious services are held or prayers are said by a congregation loyal to a belief
Synagogue (Public Venues Feature)		X	The house of worship and communal center of a Jewish congregation ¹³
Temple (Public Venues Feature)		Y	A building for Mormon sacred ordinances ¹³
Special Needs Infrastructure (Theme)		Z	Of or relating to people who have specific needs, such as those associated with a disability ¹

(continues)

Table 10.5.2 Continued

Symbol Types and Terms	Symbols	Keystroke	Definitions
Adult Day Care (Special Needs Feature)		[The locus of a nonresidential facility that provides supervision and assisted living services to adults, typically during the daylight hours
Child Day Care (Special Needs Feature)	]	A service involving care for other people's children ¹
Elder Care (Special Needs Feature)		^	The locus of a nursing home or a residential assisted-living facility in which full-time care is provided for the chronically ill, disabled, and elderly
Telecommunications Infrastructure (Theme)		‘	The electronic systems used in transmitting messages, as by telegraph, cable, telephone, radio, television, or computer ¹
Telecommunications Facility (Telecommunications Feature)		a	Any facility housing telecommunications equipment, studios, control rooms, or personnel
Telecommunications Tower (Telecommunications Feature)		b	A structure typically higher than its diameter and high relative to its surroundings to which telecommunications antennae are affixed ¹³
Transportation Infrastructure (Theme)		c	Infrastructure, means of transport, and equipment necessary for the movement of passengers and/or goods
Air Traffic Control Facility (Transportation Feature)		d	A facility operated by the appropriate authority to promote the safe, orderly, and expeditious flow of air traffic ⁸
Airport (Transportation Feature)		e	An area of land or other hard surface, excluding water, that is used or intended to be used for the landing and takeoff of aircraft and includes its buildings and facilities, if any ⁸
Bridge (Transportation Feature)		f	A structure built over a gap to connect and maintain transportation flow between both sides of the gap ¹⁵
Bus Station (Transportation Feature)		g	A terminal that serves bus passengers ²
Ferry Terminal (Transportation Feature)		h	The location of a vehicle-carrying and commuter boat line terminus ¹
Helicopter Landing Site (Transportation Feature)		i	A site within a landing zone that contains one or more points for helicopters to land ¹⁶







(continues)

Table 10.5.2 Continued

Symbol Types and Terms	Symbols	Keystroke	Definitions
Lock (Transportation Feature)		j	An enclosed part of a canal or river equipped with gates for raising or lowering the level of water so that boats and other vessels can pass ¹⁵
Maintenance Facility (Transportation Feature)		k	A location where vehicles, machines, or any other mechanical devices are serviced for inspection or repair ²
Port (Transportation Feature)		l	A location on a waterway with facilities for loading and unloading ships and other vessels ¹
Rail Station (Transportation Feature)		m	A depot where tracked transport vehicles or trains load and/or unload passengers or goods ¹⁷
Rest Stop (Transportation Feature)		n	A roadside facility at which motorists can purchase refreshments, use restrooms, and/or acquire area information
Ship Anchorage (Transportation Feature)		o	A location suitable for securely anchoring ships and other vessels ¹
Toll Facility (Transportation Feature)		p	A gate or booth at which money is collected before and/or after motorists enter or exit a toll road (turnpike) ¹⁵
Traffic Control Point (Transportation Feature)		q	The location of absolute signals controlled by an operator to regulate and maintain transportation flow
Traffic Inspection Facility (Transportation Feature)		r	Permanent facility equipped with scales where motor (shipping) vehicles transporting goods on public highways are required to stop and obtain gross vehicle and/or axle weights ¹⁸
Tunnel (Transportation Feature)		s	An underground passageway used to connect and maintain transportation flow between physical or human-built obstructions ¹⁵
Water Supply Infrastructure (Theme)		t	The storage, disinfection, filtration, and provision of drinking water to the consumer/community by means of pipelines, pumps, water towers, wells, and other appurtenances ¹⁹
Critical Valve (Water Supply Feature)		u	A valve that regulates the speed, flow, or pressure of a fluid ²⁰
Dam (Water Supply Feature)		v	A barrier constructed across a waterway to control the flow or raise the level of water ¹

(continues)

Table 10.5.2 Continued

Symbol Types and Terms	Symbols	Keystroke	Definitions
Discharge Outfall (Water Supply Feature)		w	The volume of effluent that is released into receiving waters at a given location and within a given period of time ²¹
Ground Well (Water Supply Feature)		x	An artificial excavation drilled into the ground for the purposes of withdrawing water from underground aquifers ²²
Pumping Station (Water Supply Feature)		y	Facility that lifts water up and over hills ²³
Reservoir (Water Supply Feature)		z	An off-stream water storage facility that is filled with water pumped from a river or stream ²⁴
Storage Tower (Water Supply Feature)		{	A large (usually metallic) container for holding gases or liquids ²
Surface Water Intake (Water Supply Feature)		}	A pipe through which wastewater is transferred directly to another site ²⁵
Water Treatment Facility (Water Supply Feature)		~	A place designed to receive the wastewater from domestic sources and to remove materials that damage water quality and threaten public health and safety when discharged into receiving streams or bodies of water ²²

Notes:

¹Source: Adapted from www.dictionary.com.²Source: Adapted from www.hyperdictionary.com.³Source: www.hyperdictionary.com; combined definitions of *bullion* and *storage*.⁴Source: Yahoo! Finance glossary, <http://biz.yahoo.com/f/g>.⁵Source: *Webster's New World Dictionary*; combined definitions of *firearm* and *manufacture*.⁶Source: *Webster's New World Dictionary*; combined definitions of *firearm* and *retail*.⁷Source: San Diego State University Emergency Plan glossary, <http://bfa.sdsu.edu/emergencyplan/glossary.htm>.⁸Source: Federal Aviation Administration glossary, www.faa.gov/library/glossaries.⁹Source: *Webster's New World Dictionary*; combined definitions of *pharmaceutical* and *manufacture*.¹⁰Source: Environmental Protection Agency, www.epa.gov.¹¹Source: www.hyperdictionary.com; combined definitions of *educational* and *facility*.¹²Source: Adapted from *Merriam-Webster Online* definitions of *college* and *university*.¹³Source: Adapted from *Merriam-Webster Online*.¹⁴Source: www.hyperdictionary.com; combined definitions of *generation* and *station*.¹⁵Source: Adapted from *Webster's New World Dictionary*.¹⁶Source: J. Reimer Training and Doctrine Digital Library, military terms glossary, www.adtdl.army.mil/cgi-bin/atdl.dll/fm/3-21.38/gloss.htm.¹⁷Source: www.hyperdictionary.com, adapted definition of *depot*.¹⁸Source: Nextlinx, www.nextlinx.com/global%5Fcontent/traderefs/glossary.shtml, definition of *weigh station*.¹⁹Source: County of Maui (Hawaii) Water Supply glossary, www.mauiwater.org/glossary.html, combined definitions of *water system* and *treated water*.²⁰Source: "Valve World" glossary, www.valve-world.net/glossary/index.asp, definition of *control valve*.²¹Source: Combined definitions of *outfall* from the Ohio Environmental Protection Agency glossary and *discharge* from the U.S. Geologic Survey, www.epa.state.oh.us/ddagw/documents/swapdocglo.pdf and <http://ga.water.usgs.gov/edu/dictionary.html>.²²Source: Adapted from the U.S. Geological Survey Water Science glossary, <http://ga.water.usgs.gov/edu/dictionary.html>.²³Source: Ridenbaugh Press, www.ridenbaugh.com.²⁴Source: Ohio Environmental Protection Agency glossary (term *upground reservoir*), <http://www.epa.state.oh.us/ddagw/documents/swapdocglo.pdf>.²⁵Source: U.S. Geological Survey Water Resources of New Hampshire and Vermont glossary. Combined definitions of *intake pipe* and *surface water return flow*, http://nh.water.usgs.gov/Publications/OFR01-328/ofr01-328_glossary.pdf.

Chapter 11 Emergency Evacuation Diagrams and Plans

11.1 Introduction. This chapter shall provide requirements on the preparation of floor diagrams and plans, posted within a building, to show the egress evacuation paths and locations of equipment used during an emergency. Building emergency information shall be provided to instruct or guide occupants in how to report an emergency; when to evacuate to the outside evacuation assembly area, to a designated area of refuge, to an area of rescue assistance, or to a designated shelter area; when to remain in place; or when to employ any combination of these options.

11.2 Composition.

11.2.1 The composition of the diagrams shall be clear and simple and able to be quickly understood by occupants within the building. To avoid language barriers, graphic representation and symbols shall be used.

11.2.2* A plan shall show a minimum of two ways to exit from the location of where the diagram/plan is posted, when possible, show the entire floor plan, but when unable to provide a key plan highlighting the area shown in accordance with NFPA 101. A plan shall show a minimum of two ways to exit from the location of where the diagram/plan is posted, showing the entire floor plan in accordance with NFPA 101. When unable to show the entire floor plan, provide a key plan highlighting the area.

11.2.3 The symbols of this standard shall be used to make sure that a legend is provided on the diagram/plan explaining their meaning.

11.2.4 The size of text, symbols, and information shall allow visibility by all occupants.

11.2.5 The diagram shall be located at a height above the floor to be viewable by all occupants. Diagrams shall be located such that all employees and visitors will pass by during their stay in the building.

11.3* Orientation.

11.3.1 All diagrams shall be oriented with the top in the direction that the viewer is facing.

11.3.2 There shall be a notation showing the location of the viewer and their orientation with the "you are here" notation pointing up to the sign location. This shall be the most dominant graphic on the diagram.

11.4 Information Shown.

11.4.1 The information in 11.4.1.1 and 11.4.1.2 shall be shown on the plan area of the diagram or plan. Additional information shall be permitted to be added if it does not confuse the viewer during an emergency.

11.4.1.1 The means of egress from the viewers' location shall be shown. This shall include all exit locations, exit access paths, stairways, elevators, elevator lobbies, areas of refuge, areas of rescue assistance, shelter areas, and exterior outside evacuation assembly areas.

11.4.1.2 The equipment used during an emergency shall be shown in a key or legend. This key or legend shall include fire alarm pull stations, emergency phones, defibrillators (AED), fire extinguishers (if trained to use properly), or any other building-specific emergency equipment.

11.4.2 The diagram or plan shall provide emergency phone numbers.

11.4.3 The diagram or plan shall provide emergency evacuation guidelines describing the different emergency alert signals of when and what to do when the signals are sounded. If there are not any signals, the guidelines shall describe how the occupants will be instructed what to do in case of an emergency.

11.5 Construction. The diagram shall be constructed with materials that protect it from fading and wear.

11.5.1 Materials. Diagrams shall be made of any material including photoluminescent or self-luminous, provided that an electrical charge is not required to maintain the diagram luminescence. Materials shall comply with one of the following:

- (1) ASTM E2072, *Standard Specification for Photoluminescent (Phosphorescent) Safety Markings* and ASTM E2073, *Standard Test Method for Photopic Luminance of Photoluminescent (Phosphorescent) Markings*, or
- (2) ANSI/UL 1994, *Standard for Luminous Egress Path Marking Systems*.

Annex A Explanatory Material

Annex A is not a part of the requirements of this NFPA document but is included for informational purposes only. This annex contains explanatory material, numbered to correspond with the applicable text paragraphs.

A.3.2.2 Authority Having Jurisdiction (AHJ). The phrase "authority having jurisdiction," or its acronym AHJ, is used in NFPA documents in a broad manner, since jurisdictions and approval agencies vary, as do their responsibilities. Where public safety is primary, the authority having jurisdiction may be a federal, state, local, or other regional department or individual such as a fire chief; fire marshal; chief of a fire prevention bureau, labor department, or health department; building official; electrical inspector; or others having statutory authority. For insurance purposes, an insurance inspection department, rating bureau, or other insurance company representative may be the authority having jurisdiction. In many circumstances, the property owner or his or her designated agent assumes the role of the authority having jurisdiction; at government installations, the commanding officer or departmental official may be the authority having jurisdiction.

A.3.2.4 Listed. The means for identifying listed equipment may vary for each organization concerned with product evaluation; some organizations do not recognize equipment as listed unless it is also labeled. The authority having jurisdiction should utilize the system employed by the listing organization to identify a listed product.

A.3.3.3 Referent. A referent can be abstract, such as a condition concept, function, relationship, fact, or action.

A.3.3.5 Supplementary Indicators. Effectiveness of symbols can be supplemented by figures, numbers, subscripts, or letter abbreviations. These supplementary indicators can be placed inside of, or adjacent to, the symbol as seen fit. A legend of these indicators, with their meaning, should accompany each set of documents on which they are used.

A.3.3.6 Symbol. Ideally, a symbol should be graphically simple, should be readily understood, should have a strong impact, and should be easily remembered.

A.4.1.2.3 Changes in line thickness, scale, or details are not recommended. In practice, symbols can be combined with other symbols or devices such as words and lighted panels to provide optimal visual alerting. This chapter does not specify viewing distance, size, or optimal combinations of symbols, words, or other presentations. The user is referred to other standards, such as those prepared by the NFPA Committee on Safety to Life and the ANSI Z535 Committee on Safety Signs and Colors, for such information.

A.4.1.3 Reflective material or self-luminous or photoluminescent materials can be used. Consideration needs to be given to the proper mounting of self-luminous or photoluminescent symbols in well-lighted locations to ensure charging by exposure to ambient light.

A.4.1.3.2.1 See Figure A.4.1.3.2.1.

A.4.1.3.4 Examples of combinations of symbols that can be used include Exit Symbol Arrow, Exit Symbol with International Symbol of Accessibility, and Exit Symbol with Arrow and International Symbol of Accessibility.

A.4.2 Use of the symbols is not restricted to the examples cited.

A.5.1.1 The purpose of this chapter is to present uniform fire-fighting symbols in order to improve communication wherever symbology is employed in order to provide information to fire fighters and other emergency responders.

This chapter provides uniformity in the selection of symbols that are intended to assist fire fighters in locating utilities and fire-fighting equipment.

A.5.1.2 In practice, symbols can be combined with other devices, such as words and lighted panels, to provide optimal visual alerting. This chapter does not specify viewing distance, size, or optimal combinations of symbols, words, and other presentations.

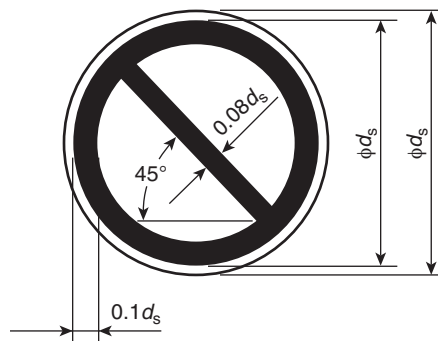

The colors of the sign shall be as follows:

Background color:	white
Circular band and diagonal bar:	red
Graphical symbol:	black
Border:	white

The safety color red shall cover at least 35 percent of the total area of the sign.

FIGURE A.4.1.3.2.1 Example of a Prohibition Symbol.

A.5.1.3 Reflective material or self-luminous or photoluminescent materials can be used. Consideration needs to be given to the proper mounting of self-luminous or photoluminescent symbols in well-lighted locations to ensure charging by exposure to ambient light.

A.5.1.3.1 Drawing scale, line thickness, and so forth are the subject of standards on drawing practice.

A.5.2 Use of the symbols is not restricted to the examples cited.

The symbol for fire hydrant (all types) shown in Table 5.2 can be of particular use where vehicles or snowfall frequently obscures hydrant locations.

A.6.1 This chapter on architectural and engineering symbols draws heavily on the symbols already developed by various societies, agencies, and industry.

The purpose of this chapter is to provide uniformity in the use of fire safety and related symbols in the preparation of drawings and diagrams.

The symbols in this chapter are intended to be simple, transferable by use of templates, and limited to those referents that are used repetitively in a set of drawings.

The symbols in this chapter are intended for, but not limited to, architectural and engineering drawings, fire detection and suppression drawings, and fire risk and/or loss analysis diagrams.

The effectiveness of the symbols in this chapter can be enhanced by the use of supplementary figures, subscripts, numbers, or letter abbreviations.

Devices infrequently used in a given set of drawings and diagrams are not standardized by this document. They usually are accompanied by narrative description, either on the drawing or in specifications.

A.6.1.2 Where appropriate, diagrams include, but are not limited to, the following (see Figure A.6.1.2):

- (1) Title block indicating the following:
 - (a) Name of company or organization
 - (b) Person making drawing and date of drawing
 - (c) Name and location of facility involved
- (2) “North” direction arrow properly oriented to the position of buildings shown.
- (3) Scale of diagram, if used, or “not to scale.” Scale can be given with a bar measurement if reduction copies are to be made.

A.6.1.2.1 Drawing scale, line thickness, and so forth, are the subject of standards on drawing practice.

A.6.1.2.4 See Figure A.6.1.2.4(a) and Figure A.6.1.2.4(b) for examples of symbol orientation.

A.6.2.1.2 See Figure A.6.2.1.2 for examples of open-walled structures.

A.6.2.3 See Figure A.6.2.3 for an example of a street.

A.6.2.4 See Figure A.6.2.4 for examples of bodies of water.

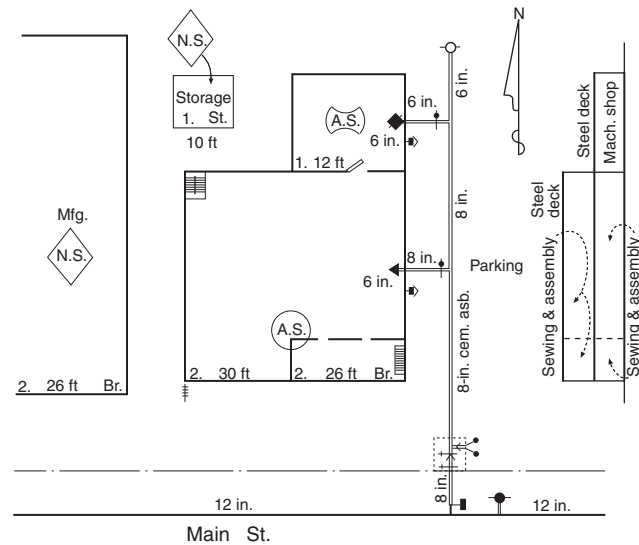

For SI units: 1 in. = 25 mm; 1 ft = 0.305 m.

FIGURE A.6.1.2 Example of the Use of Symbols for Risk Analysis Diagram.

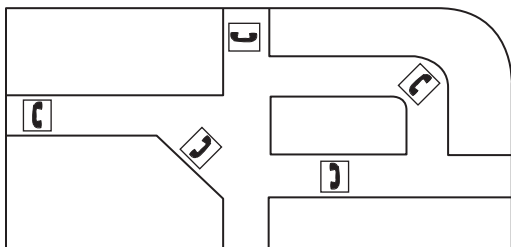

FIGURE A.6.1.2.4(a) Symbol Orientation — Example 1.

A.6.2.5.2 See Figure A.6.2.5.2 for an example of a fence with a gate.

A.6.3.1 See Figure A.6.3.1 for an example of building construction identification. (See NFPA 220.)

A.6.3.2 See Figure A.6.3.2 for an example of height symbols used for a building.

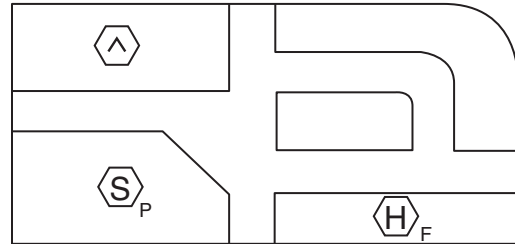

FIGURE A.6.1.2.4(b) Symbol Orientation — Example 2.

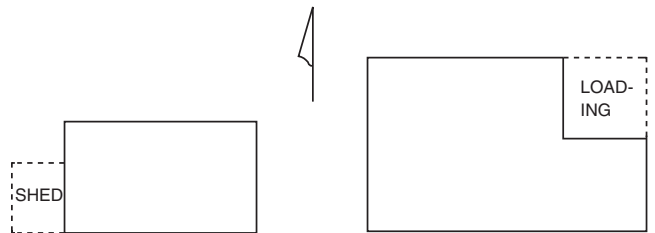

FIGURE A.6.2.1.2 Examples of Open-Walled Structures.

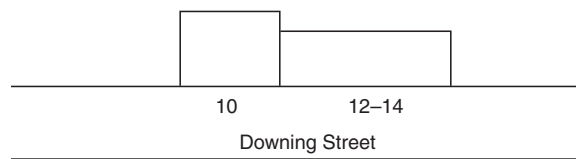

FIGURE A.6.2.3 Example of a Street.



FIGURE A.6.2.4 Examples of Bodies of Water.



FIGURE A.6.2.5.2 Example of a Fence with a Gate.

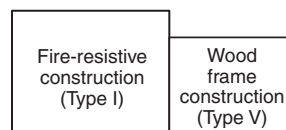

FIGURE A.6.3.1 Example of Building Construction Identification.

A.6.3.3 See Figure A.6.3.3(a) and Figure A.6.3.3(b) for examples of wall symbols.

See Figure A.6.3.3(a) for examples of parapet symbols used for a building.

A.6.3.5 See Figure A.6.3.5 for an example of cross-section symbols used for a building.

A.7.1 See A.6.1.

A.7.1.2 See A.6.1.2.

A.7.1.2.1 See A.6.1.2.1.

A.7.1.2.4 See A.6.1.2.4.

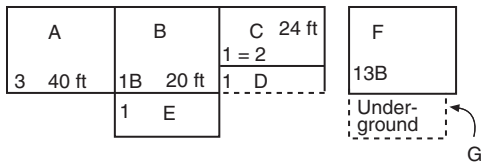

- A Three stories, no basement, 40 ft to eaves
- B One story with basement, 20 ft to eaves
- C One-equals-two stories, no basement, 24 ft to eaves
- D One-story open porch or shed
- E One-story addition
- F Thirteen stories with basement
- G Underground structure

FIGURE A.6.3.2 Examples of Building Height Symbols. (Figure includes copyrighted material of Insurance Services Office with its permission. Copyright, Insurance Services Office, 1975.)

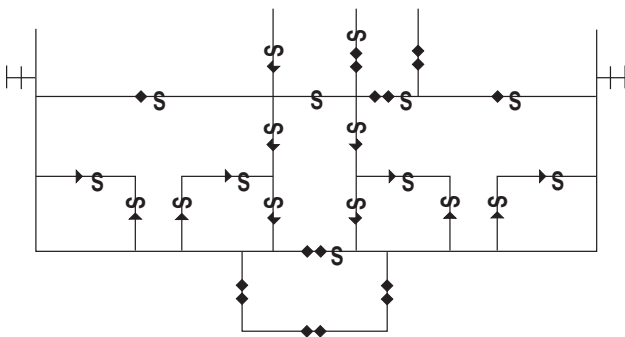

FIGURE A.6.3.3(a) Symbols Used to Note Wall Ratings and Parapets on Life Safety Plans and Risk Analysis Plans and Cross-Sections.

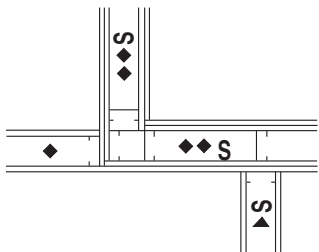

FIGURE A.6.3.3(b) Symbol Used to Note Wall Ratings on Design and Construction Documents.

A.7.2 For private hydrant, one hose outlet; public hydrant, two hose outlets; public hydrant, two hose outlets and pumper connection; wall hydrant, two hose outlets; and private housed hydrant, two hose outlets, all shown in Table 7.2, symbol elements can be utilized in any combination to fit the type of hydrant.

A.7.6 These symbols are intended for use in identifying the type of system installed to protect an area within a building.

A.7.6.2.1 Temperature ratings for sprinklers used throughout occupancies should be designated in the plan legend. When sprinklers with various temperature ratings are installed, the sprinkler ratings should be designated as in Table A.7.6.2.1. For example, a note on the drawing may state “all sprinklers are 155°F unless noted.”

A.7.6.3 See also Table 7.2 for related symbols.

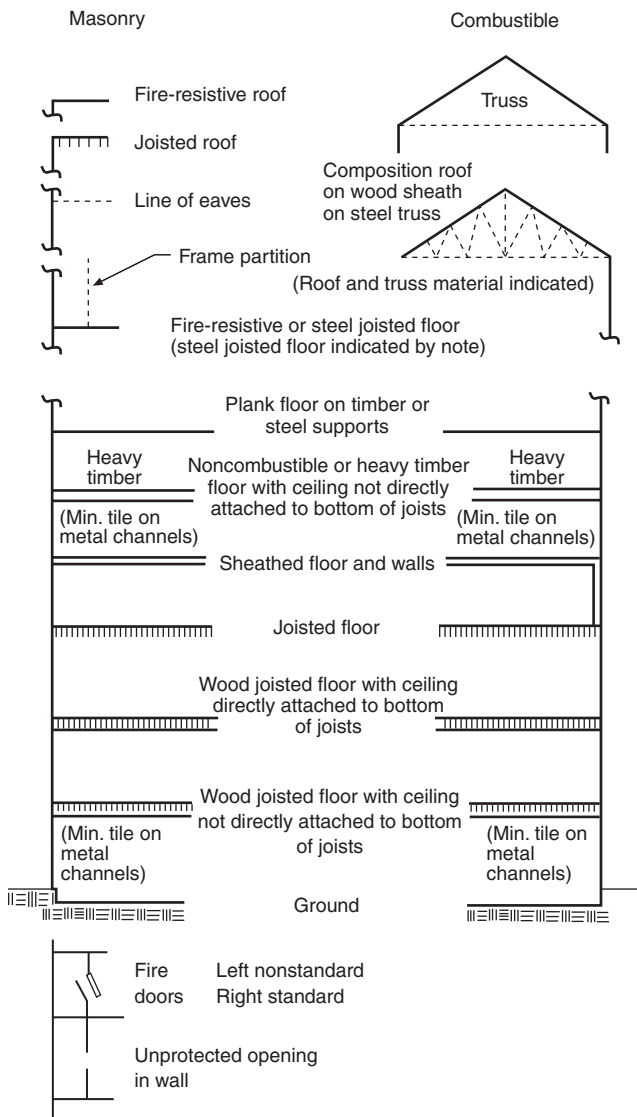



FIGURE A.6.3.5 Examples of Symbols and Notations Used for Fire Risk Analysis Cross Section. (Figure includes copyrighted material of Insurance Services Office with its permission. Copyright, Insurance Services Office, 1975.)

Table A.7.6.2.1 Symbols for Fire Sprinklers

Symbol	Description
	Upright on sprig @ 200°F temperature
	Pendent on drop @ 286°F temperature

A.7.9 The electrothermal link (ETL) is a multipurpose dual-response fusible link/release device. These devices are used in various applications, such as smoke/damper control and door closures. The symbol should be shown with its rated thermal point.

A.8.1 See A.6.1.

A.8.1.2 See A.6.1.2.

A.8.1.2.1 See A.6.1.2.1.

A.8.1.2.4 See A.6.1.2.4.

A.8.3 Additional subscript identifiers can be included with a slash after the primary subscript to indicate such things as, for example, WP for weatherproof or EP for explosionproof.

For the manual station symbol shown in Table 8.3, electrical or mechanical actuation can be shown.

See NFPA 2001 for a generic list of clean agents.

The telephones referred to in the fire service or emergency telephone station symbols, shown in Table 8.3, are those for a dedicated system for fire and related emergencies.

Temperature rating of heat detectors, in Table 8.3, can be shown.

Velocity can be shown for the smoke detector for duct symbol shown in Table 8.3.

For the gas detector symbol shown in Table 8.3, the drawing should show the type of gas or gases being monitored. The drawing should indicate the lower explosive limit (LEL) and/or the upper explosive limit (UEL) of gas or gases.

A.9.1.1 The purpose of this chapter is to provide uniformity in the use of fire safety and related symbols in the preparation of pre-incident planning sketches.

The symbols in this chapter are provided to assist fire service or emergency response personnel who are responsible for preparing and using pre-incident planning sketches.

A.9.1.2 Triangle symbols are used for access features, assessment features, ventilation features, and utility shutoffs and can point at a specific location or direction. Diamond symbols identify a specific location by touching a wall. Circle symbols are used for all piping system components, such as valves, since most pipes are round.

Square symbols are used for room designations, as they represent most rooms having four sides.

A.9.2 For Section 9.2 through Section 9.5, other features to complete the pre-incident planning sketch can be used as appropriate.

A.9.6 Figure A.9.6 shows an example of hazardous identification.

A.11.2.2 It is advisable to show the whole building floor plan with all exits, when possible.

A.11.3 See Figure A.11.3.

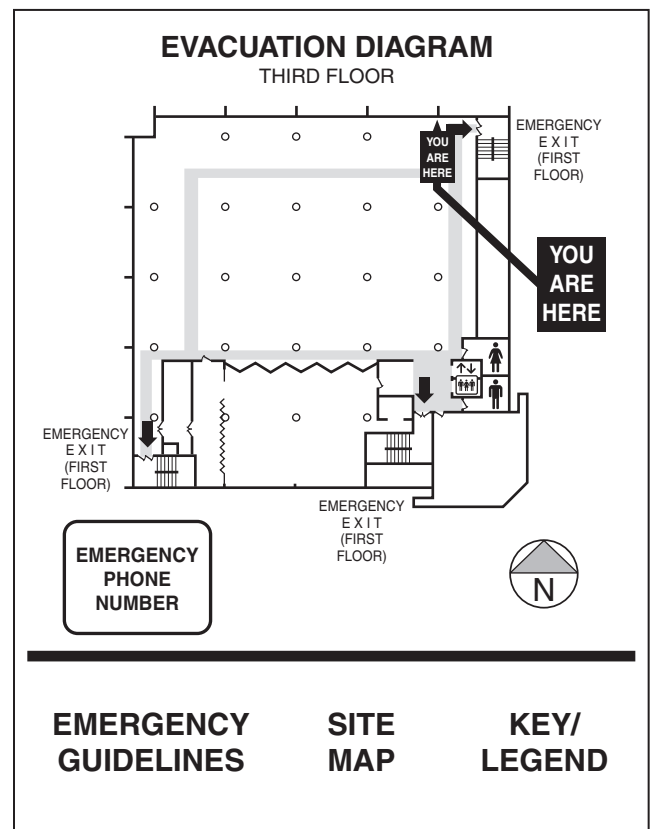
**FIGURE A.9.6 Example of Hazardous Identification.****FIGURE A.11.3 Example of Proper Orientation.**

Annex B Additional Explanatory Information on Chapters 1 Through 6

This annex is not a part of the requirements of this NFPA document but is included for informational purposes only.

B.1 Reserved.

B.2 Reserved.

B.3 Additional Explanatory Information on Chapter 4.

B.3.1 Symbol Testing. Two or more versions of a symbol were developed for the referents listed in Chapter 4. The effectiveness of each of these symbols was evaluated by testing its meaningfulness (i.e., understandability) with groups of different participants. On the basis of these results, a symbol was selected for each referent. In some cases, the symbols were refined graphically to incorporate modifications suggested by the test results. Symbol development and refinement included the efforts of research psychologists, graphic designers, safety engineers, and fire professionals.

The life safety symbols were tested in the course of several different research projects during a 7-year period. These results are referenced in a series of publications by the National Bureau of Standards.

Although a variety of testing procedures were used to assess understandability, the basic method consisted of asking people either to write down short definitions or to pick the correct definition from a set of carefully selected choices. In several studies, data on symbol preference and rated effectiveness also were obtained.

For these testing efforts, one set of participants consisted of 222 industrial personnel and 78 students; another set consisted of 271 miners and mine personnel; and another set consisted of 94 paid volunteers. No major differences between participant groups were observed for the symbols selected for Chapter 4.

In addition to the studies of understandability, a detailed assessment was made of exit symbol visibility. This study used a laboratory optical viewing system to present a set of exit symbols included in a much larger set (108) of safety and information symbols. Three viewing conditions that simulated smoke were used (luminance of 0.085, 0.060, and 0.032 candela/m²). Forty-two participants were familiarized with a randomly selected set of exit symbols to identify the separate effects of understandability and visibility. The symbol given in Chapter 4 was the symbol that was most frequently identified correctly under all three viewing conditions. In addition, the identification data were virtually the same whether participants had been familiarized with the symbol or not — suggesting that the symbol has high initial understandability. (This suggestion is reinforced by the high percentages of correct identification found in those studies that evaluated understandability.)

The results of the visibility testing program are important because an exit symbol must be both well understood and visible when under degraded viewing conditions such as smoke.

The goal of the overall testing program was to identify versions or elements of symbols for the selected referents that appeared to be most effective in communicating the intended message. It is recognized that further education and/or supplemental word messages can be useful in optimizing the effectiveness of these symbols with the general public. Nevertheless, the

symbols selected have demonstrated good initial understandability. Symbols for the referents generally showed good understandability (better than 85 percent correct identification). Symbols that presented some understandability problems included “No Exit” and “Fire Alarm Call Point.” The examples shown herein, however, represent the imagery that was best understood. It is hoped that use of these images will strengthen public recognition.

It also should be noted that the symbol for handicapped accessibility was not tested in this program. It is, however, in an existing ICC/ANSI standard, A117.1, *Specifications for Making Buildings and Facilities Accessible to and Usable by Physically Handicapped People*, and has achieved wide use and good recognition.

B.4 Additional Explanatory Information on Chapter 5.

B.4.1 Symbol Testing. At least two versions of a symbol were developed for each of the following referents:

- (1) Fire department automatic sprinkler connection — siamese
- (2) Fire department standpipe connection
- (3) Fire department combined automatic sprinkler/standpipe connection
- (4) Fire hydrant (all types)
- (5) Automatic sprinkler control valve
- (6) Electric panel or electric shutoff

The following referents are discussed in this section:

- (1) Gas shutoff valve
- (2) Fire-fighting hose or standpipe outlet
- (3) Fire extinguisher
- (4) Directional arrow
- (5) Diagonal directional arrow

Subsequently, the effectiveness of the symbols was evaluated by testing their meaningfulness to groups of fire professionals; the procedures are outlined in this section. On the basis of the test results, a symbol was selected for each referent. This set of symbols was further refined graphically, incorporating modifications suggested by the test results. Symbol development and refinement through a Subcommittee on Visual Alerting Symbols included the efforts of fire professionals, graphic artists and designers, research psychologists, and safety engineers.

Symbols for gas shutoff valve, fire-fighting hose or standpipe outlet, fire extinguisher, directional arrow, and diagonal directional arrow were adapted from International Organization for Standardization (ISO) publications. The fire extinguisher symbol was included in the test procedure. Although the standpipe outlet symbol was not tested in isolation, it was incorporated as an element in two of the tested symbols (fire department standpipe connection and fire department combined automatic sprinkler/standpipe connection).

Participants in the test program included fire professionals attending a national convention or local (Maryland) training classes and totaled 86 participants. The test procedure involved two phases. In the first phase, the participants were shown one symbol at a time, in slide form, and were asked to write down a short definition of what they thought each symbol meant. In the second phase, two symbolic versions of each referent were shown together, and their intended meaning was provided; the participants indicated which version (if either) of each pair they felt better conveyed the meaning. They also were asked to

give the reason for their preference and were free to offer any suggestions for improvement.

The goal of the testing program was to identify versions or elements of symbols for the selected referents that were most effective in visually alerting fire fighters. It is recognized that education might be required to optimize the effectiveness of the symbols for fire fighters. Nevertheless, it is important to select symbols that initially are meaningful. Symbols for seven of the nine referents tested showed good recognizability (85 to 100 percent) and no serious confusion with other possible meanings. However, for two referents — wall hydrant and gas control valve — recognition was poor, and confusion was common for both symbolic versions of each message. Therefore, no symbol for these two referents is presented in this standard. Graphic improvements and alternative conceptions are being sought. (A symbol for a gas shutoff valve was accepted for the 1991 edition of NFPA 170.)

B.4.2 The NFPA Committee on Fire Safety Symbols was able to identify a set of shapes for symbols to be used to direct responding fire fighters.

B.5 Additional Explanatory Information on Chapter 6.

B.5.1 Symbol Selection Procedure. See Figure B.5.1 for an example of the procedures involved in selecting fire safety symbols.

B.5.2 Discussion of Basic Symbols.

B.5.2.1 Symbol Testing. Inevitably, when a new standard is introduced to a field in which standardized symbols are not established and everyone is acting independently, controversy looms over the effort as to which (whose) alleged “standard” should be used. Such controversy can be met only with a national logic for meeting the standardization task. Such logic was used in developing former NFPA 172 now incorporated into Chapter 6.

B.5.2.2 This symbology effort ultimately employed the following steps:

- (1) Identify problem. Is a standard for fire protection symbols needed?
- (2) Identify referents. What devices should be symbolized? Consider applicability to fire protection and frequency of use.
- (3) Identify symbols’ availability. What symbols exist, and how widely are they used for fire protection and other disciplines?
- (4) Develop a system of symbol selection. Can a system be identified so that referents and symbols can be rationally selected or developed? (*See B.5.1.*)
- (5) Can a scheme of basic shapes be utilized in developing symbol sets for categories of referents?
- (6) Adhere to the scheme. Make exceptions only where an overwhelming level of usage makes changes unreasonable.
- (7) Avoid conflicts. Are there other practices and/or standards with which the proposed standard might be in conflict?

B.5.2.3 To accomplish step B.5.2.2(5), two factors had to be considered. First, there is very little agreement on symbols throughout North America. For the most part, various industry segments disagree on symbols and even on basic shapes. Second, the ISO Committee on Fire Protection Symbols for Use on Drawings completed most of its work on this subject before 1980 and proposed a set of basic symbol shapes.

B.5.2.4 With the two foregoing considerations, the NFPA Committee on Fire Safety Symbols was able to develop a set of basic shapes for symbols to be used on fire protection drawings. The basic shapes shown in Table B.5.2.4 were selected by uniting the ISO-proposed basic shapes and, where existent, the North American common practice. Thus, the collection of shapes (menu) represents a compromise with the sole major objective of developing a symbols standard aimed at a common language to improve future communication among users of fire protection drawings worldwide.

B.5.2.5 The collection of basic shapes in Table B.5.2.4 is broken down into a major classification of symbol elements and a supplementary set of symbol elements that can be used singly or in combination with other symbol elements. These basic symbol shapes and relative sizes are not exclusive of all the shapes and sizes that were used in developing former NFPA 172 (now incorporated into Chapter 6). They are a guide that was used in developing the family scheme.

It is recognized that the former NFPA 172 did not include all the fire safety symbols that can be required on architectural and engineering drawings. Table B.5.2.4 can therefore be used as a basis for future development of Chapter 6 or for the design of specialized symbols by the draftsman.

Symbol elements have definite meanings and therefore should always be represented at the same relative size when used in different symbols.

B.5.2.6 The NFPA Committee on Fire Safety Symbols was able to identify a set of shapes for symbols to be used on fire protection drawings and diagrams (*see Table B.5.2.4*). The shapes were selected through a reconciliation of the symbols presented in the former NFPA 172 (now incorporated into Chapter 6), the general shapes being drafted by the ISO, and, where existent, the common practice in North America. Thus, the family of shapes represents a compromise, with the major objective of developing a common language to improve future communication among users of fire protection diagrams worldwide.

B.5.3 Use of Color Coding.

B.5.3.1 General. The use of color coding to indicate various types of building construction is recommended and can be justified. Where used, color coding should be in conformity with this annex to maximize communication. Where color coding is not used, it is necessary to rely on printed detail.

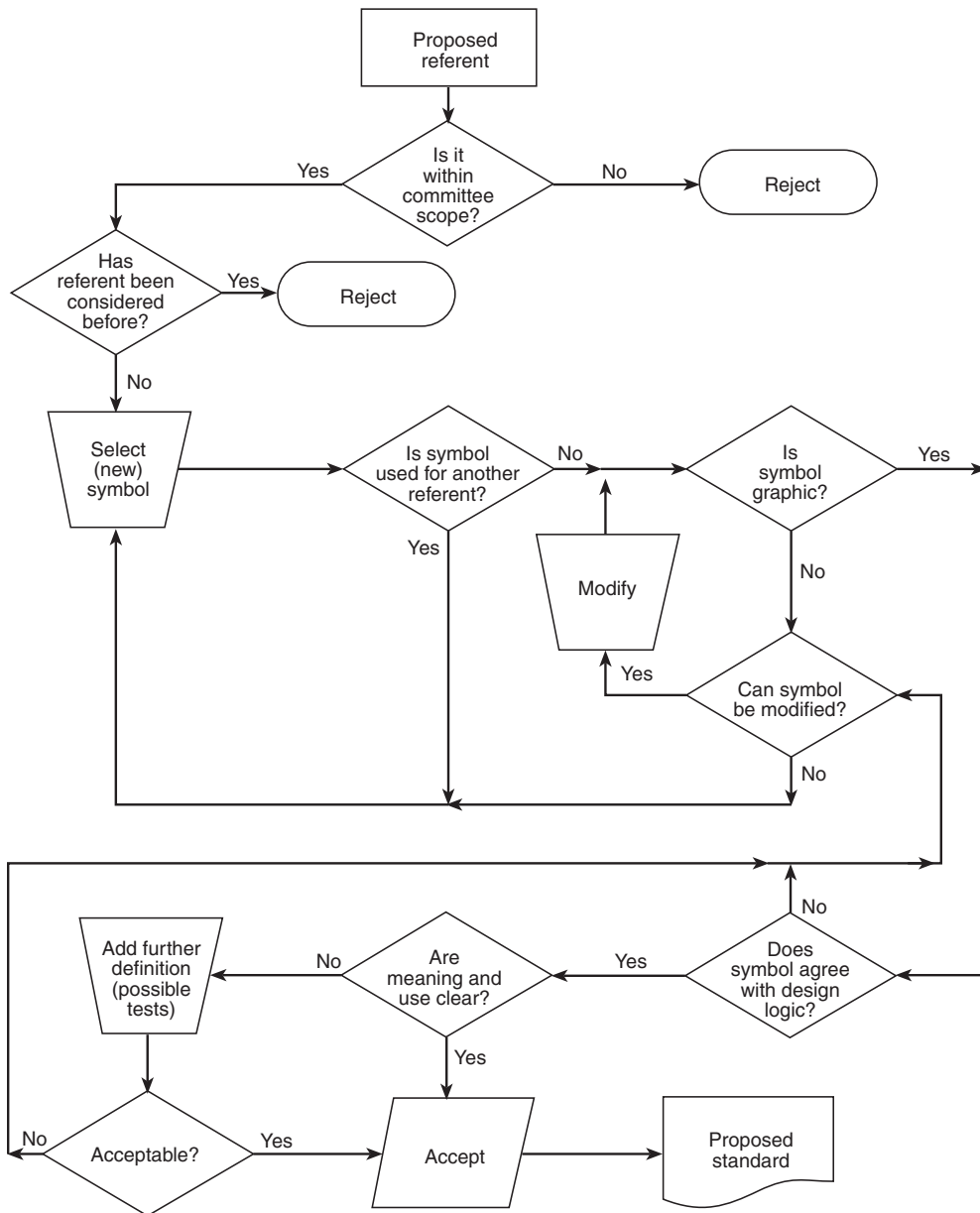





















FIGURE B.5.1 Symbol Selection Procedure.

Table B.5.2.4 Basic Symbol Shapes and Relative Sizes

General Referent	Shape	Relative Size*	Comments
Major Elements			
Automatically actuating systems		4 mm ($\frac{5}{32}$ in.) diameter	Detection, extinguishment
Manually actuating systems		4 mm ($\frac{5}{32}$ in.) square	Manual alarm system
Control panel		4 mm × 8 mm ($\frac{5}{32}$ in. × $\frac{5}{16}$ in.)	Supplementary element used to describe the panel
Portable fire extinguisher		5 mm ($\frac{3}{16}$ in.) sides	Supplementary element used to further describe the extinguisher
Fire-fighting equipment		6 mm ($\frac{1}{4}$ in.) sides	Supplementary element used to describe a specific device
Supplementary Elements			
Water system components		2 mm ($\frac{3}{32}$ in.) diameter	General shape, a circle; shading of element indicates wet device
Foam agent		5 mm ($\frac{3}{16}$ in.) diameter	
Dry chemical agent		2 mm ($\frac{3}{32}$ in.) square	
Gaseous agent		3 mm ($\frac{1}{8}$ in.) sides	
Nozzle			Used on pipe or other symbol
Pressure notation			Used with another symbol shape, such as a detector or a tank
Switch (electrical) or contact		2 mm ($\frac{5}{64}$ in.) diameter	
Valve		4 mm ($\frac{5}{32}$ in.) high	
Check valve		6 mm ($\frac{1}{4}$ in.) high (with arrow)	
Tamper detector		4 mm ($\frac{5}{32}$ in.) diameter	
Heat detector		1 mm ($\frac{3}{64}$ in.) diameter	
Flow detector		4 mm ($\frac{5}{32}$ in.) high	
1-hour fire rating		5 mm ($\frac{3}{16}$ in.) square	Used to indicate fire rating of walls in hours
Automatic detection and supervisory use devices		5 mm ($\frac{3}{16}$ in.) sides	Detection, supervisory

**Relative* is emphasized because it is not the intent here to specify actual dimensions. For comparisons, this column lists the suggested sizes of the symbols presented here.

B.5.3.2 Table B.5.3.2 presents a recommended system for color coding.

Table B.5.3.2 Color Coding of Construction Types

Construction Type*	Color
Fire resistive (Type I)	Light brown
Noncombustible/limited combustible (Type II)	Gray (brown border if masonry walls)
Heavy timber and ordinary (Type III and IV)	Pink
Wood frame (Type V)	Yellow

*See NFPA 220.

Annex C Emergency Responder Map

This annex is not a part of the requirements of this NFPA document but is intended for informational purposes only.

C.1 Emergency Responder Plan. The plan shown in Figure C.1(a) and Figure C.1(b) provides emergency responders an example of maps showing the interior and exterior locations of the building using the symbols from Table 5.2 and information from Chapter 9. See Figure C.1(a) and Figure C.1(b).

BUILDING TITLE
ADDRESS
EMERGENCY RESPONSE MAP
 FIRST FLOOR - INTERIOR

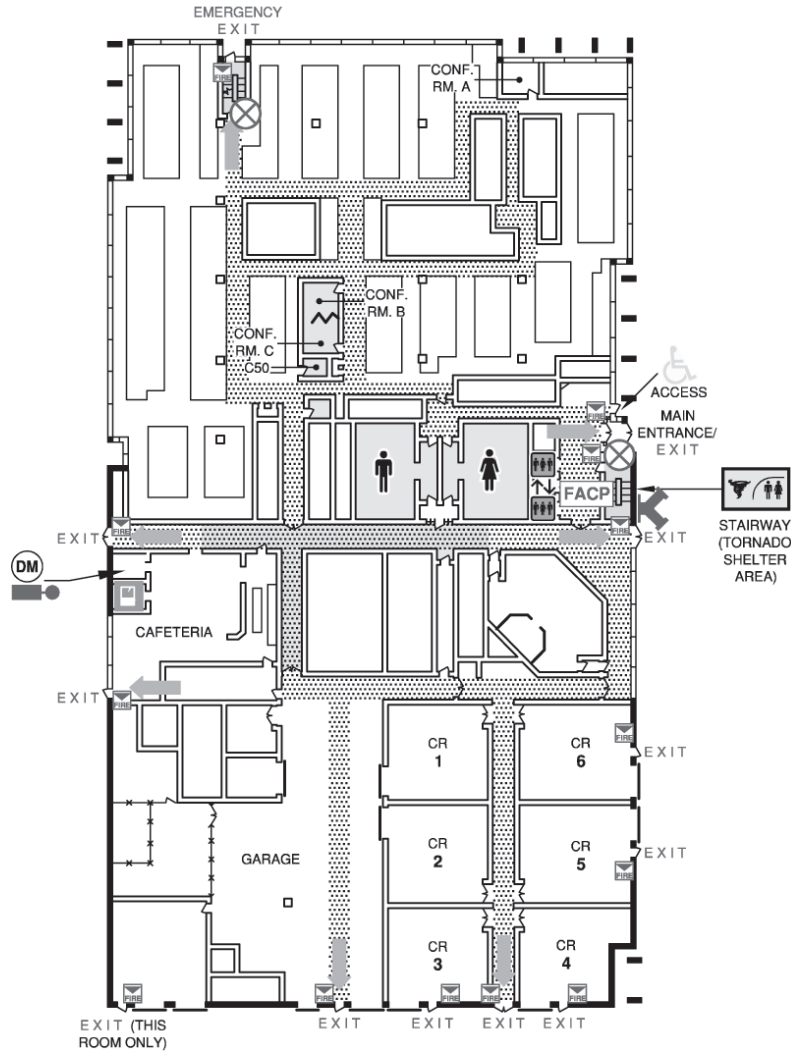

BUILDING NOTES:					
Fire Department standpipes are located in each stairway					
LEGEND					
Fire Pump	Fire Hydrant	Main Gas Service Shutoff	Fire Suppression Pull		
Fire Alarm Control Unit	Fire Dept. Connection	Main Electrical Service Shutoff	Special Fire Protection		
Non-Sprinklered	Riser Valve	Domestic Water shutoff	Elevator	Tornado Shelter Area	
Fire Dept. Standpipe Valve	Fire Dept. Access	Stairway	Evacuation Assembly Area		



FIGURE C.1(a) Emergency Response Map First Floor, Interior.

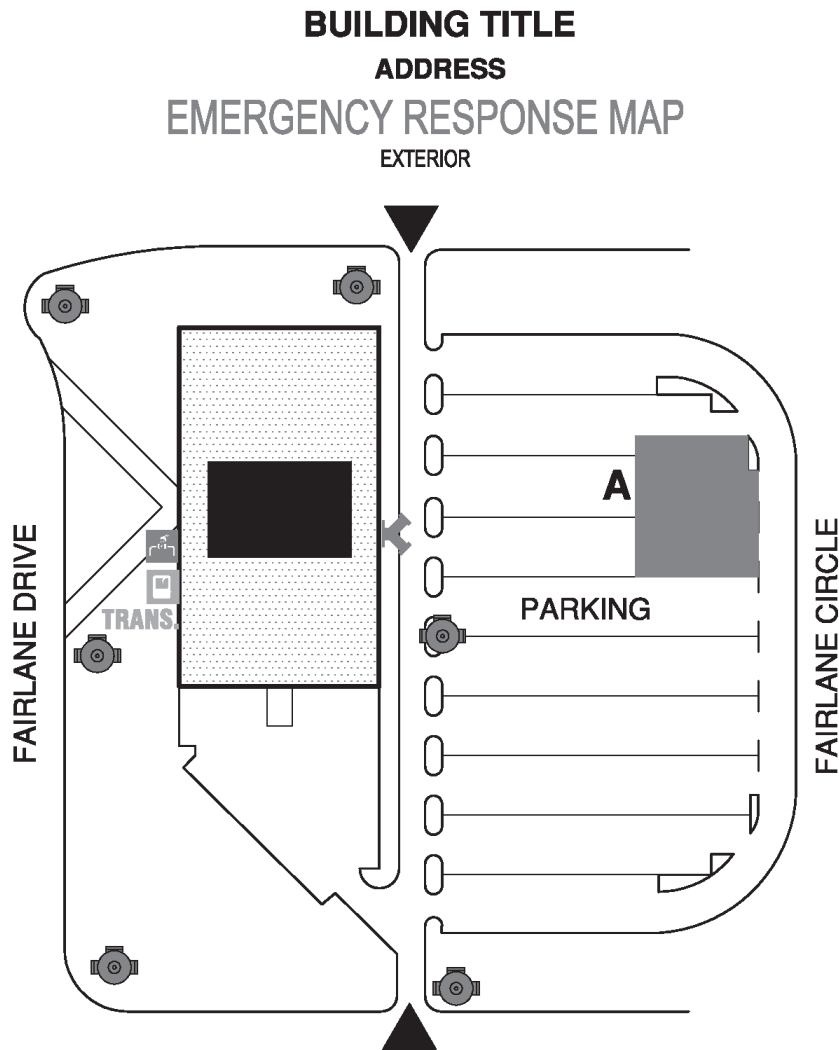

BUILDING NOTES:				
Fire Department standpipes are located in each stairway				
LEGEND				
Fire Pump	Fire Hydrant	Main Gas Service Shutoff	Fire Suppression Pull	
Fire Dept. Connection	Main Electrical Service Shutoff	Special Fire Protection		
Fire Alarm Control Panel	Riser Valve	Domestic Water shutoff	Elevator	
Non-Sprinklered	Fire Dept. Standpipe Valve	Fire Dept. Access	Stairway	Evacuation Assembly Area



FIGURE C.1(b) Emergency Response Map Exterior.

Annex D Fire Fighter Safety Building Marking System

This annex, which is extracted from NFPA 1, Annex E, is not a part of the requirements of this NFPA document unless specifically adopted by the AHJ.

D.1 Fire Fighter Safety Building Marking System (FFSBMS). [1:E.1]

D.1.1 General. [1:E.1.1]

D.1.1.1 The fire fighter safety building marking system provides basic building information for fire fighters responding to the building or structure.

[1:E.1.1.1]

D.1.1.2 Where required by the AHJ, buildings and structures shall have the fire fighter safety building marking system sign installed.

[1:E.1.1.2]

D.1.2 Sign. [1:E.1.2]

D.1.2.1 The approved fire fighter safety building marking system sign shall be placed in a position to be plainly legible and visible from the street or road fronting the property or as approved by the fire department.

[1:E.1.2.1]

D.1.2.2 The fire fighter safety building marking system sign shall consist of the following:

- (1) White reflective background with black letters
- (2) Durable material
- (3) Arabic numerals or alphabet letters
- (4) Permanently affixed to the building or structure in an approved manner

[1:E.1.2.2]

D.1.2.3 The fire fighter safety building marking system shall be a Maltese cross as shown in Figure D.1.2.3.

[1:E.1.2.3]



FIGURE D.1.2.3 Sample Sign for Fire Fighter Safety Building Marking System. [1:Figure E.1.2.3]

D.1.2.4 The minimum size of the fire fighter safety building marking system sign and lettering shown in Figure D.1.2.4 shall be in accordance with the following or as approved by the fire department:

- (1) A shall be 5 in. × 5 in.
- (2) B shall be 1¼ in.
- (3) C shall be 2½ in.
- (4) Letters shall be 1 in. height with a stroke of ¼ in.

[1:E.1.2.4]

D.1.3 Ratings. [1:E.1.3]

D.1.3.1 Ratings shall be determined by the construction type, hazards of contents, automatic fire sprinkler systems and stand-pipe systems, occupancy/life safety, and special hazards in accordance with this section.

[1:E.1.3.1]

D.1.3.1.1 Where multiple ratings occur within a classification category, a determination shall be made by the AHJ of the rating that shall be based on the greatest potential risk for the specific category. (See Note 1 in D.2.1.)

[1:E.1.3.1.1]

D.1.3.2 Construction Type. The construction type shall be designated by assigning the appropriate lettering to the top of the Maltese cross as follows:

- (1) FR — Fire-resistive construction
- (2) NC — Noncombustible construction
- (3) ORD — Ordinary construction
- (4) HT — Heavy timber construction
- (5) C — Combustible construction

[1:E.1.3.2]

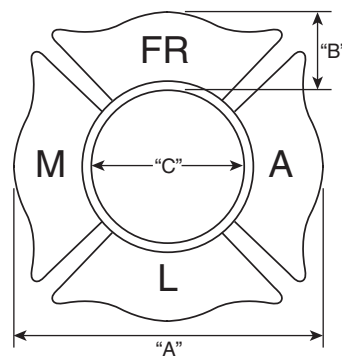

FIGURE D.1.2.4 Dimensions for Fire Fighter Safety Building Marking System Signs. [1:Figure E.1.2.4]

D.1.3.3 Hazards of Contents. The hazards of contents shall be rated by determining its hazard and assigning the appropriate rating to the left of the Maltese cross as follows (*see Note 2 in D.2.2*):

L — Low hazard. Low hazard contents shall be classified as those of such low combustibility that no self-propagating fire therein can occur.

M — Moderate hazard. Moderate hazard contents shall be classified as those that are likely to burn with moderate rapidity or to give off a considerable volume of smoke.

H — High hazard. High hazard contents (*see Note 3 in D.2.3*) shall be classified as those that are likely to burn with extreme rapidity or from which explosions are likely.

[1:E.1.3.3]

D.1.3.4 Automatic Fire Sprinkler and Standpipe System. The automatic fire sprinkler system and standpipe system shall be rated by determining its level of protection and assigning the appropriate rating to the right of the Maltese cross. If multiple systems are provided, all systems shall be included in the Maltese cross as follows:

- (1) A — Automatic fire sprinkler system installed throughout
- (2) P — Partial automatic fire sprinkler system or other suppression system installed
- (3) S — Standpipe system installed
- (4) N — None

[1:E.1.3.4]

D.1.3.5 Occupancy/Life Safety Issues. The occupancy/life safety type shall be rated by determining the level of difficulty in evacuating occupants from the building and the occupancy type by assigning the appropriate rating to the bottom of the Maltese cross as follows:

- (1) L — Business, industrial, mercantile, residential, and storage occupancies
- (2) M — Ambulatory health care, assembly, educational, and day care occupancies
- (3) H — Detention and correction facilities, health care, and board and care occupancies

[1:E.1.3.5]

D.1.3.6 Special Designations. The special hazards can be assigned to the center of the Maltese cross (*see Note 4 in D.2.4*).

[1:E.1.3.6]

D.2 Notes. The following notes are explanatory and are not part of the mandatory text for Annex D.

[1:E.2]

D.2.1 Note 1. An example of the greatest potential risk for construction type where an FR and an NC are present, the ranking on the FFSBMS sign would be NC.

[1:E.2.1]

D.2.2 Note 2. Hazard of contents are described as follows:

Low hazard recognizes storage of noncombustible materials as low hazard. In other occupancies it is assumed that, even where the actual contents hazard is normally low, there is sufficient likelihood that some combustible materials or hazardous operations will be introduced in connection with building repair or maintenance, or some psychological factor might

create conditions conducive to panic, so that the egress facilities cannot safely be reduced below those specified for ordinary hazard contents. Moderate hazard classification represents the conditions found in most buildings and is the basis for the general requirements of this *Code*.

The fear of poisonous fumes or explosions is necessarily a relative matter to be determined on a judgment basis. All smoke contains some toxic fire gases but, under conditions of moderate hazard, there should be no unduly dangerous exposure during the period necessary to escape from the fire area, assuming there are proper exits.

[1:E.2.2]

D.2.3 Note 3. High hazard contents include occupancies where flammable liquids are handled or used or are stored under conditions involving possible release of flammable vapors; where grain dust, wood flour or plastic dust, aluminum or magnesium dust, or other explosive dusts are produced; where hazardous chemicals or explosives are manufactured, stored, or handled; where cotton or other combustible fibers are processed or handled under conditions producing flammable flyings; and other situations of similar hazard.

[1:E.2.3]

D.2.4 Note 4. The center of the fire fighter safety building marking system sign has been left empty to permit the local jurisdiction space to provide for additional information that they may wish to add. The NFPA 704 marking system can be incorporated into the center of the fire fighter safety building marking system sign if all the applicable provisions of NFPA 704 are met including lettering size and so forth.

[1:E.2.4]

Annex E Informational References

E.1 Referenced Publications. The documents or portions thereof listed in this annex are referenced within the informational sections of this standard and are not part of the requirements of this document unless also listed in Chapter 2 for other reasons.

E.1.1 NFPA Publications. National Fire Protection Association, 1 Batterymarch Park, Quincy, MA 02169-7471.

NFPA 220, *Standard on Types of Building Construction*, 2015 edition.

NFPA 704, *Standard System for the Identification of the Hazards of Materials for Emergency Response*, 2017 edition.

NFPA 2001, *Standard on Clean Agent Fire Extinguishing Systems*, 2015 edition.

E.1.2 Other Publications.

E.1.2.1 ANSI Publications. American National Standards Institute, Inc., 25 West 43rd Street, 4th Floor, New York, NY 10036.

ICC/ANSI A117.1, *Accessible and Usable Buildings and Facilities*, 2009.

E.2 Informational References. The following documents or portions thereof are listed here as informational resources only. They are not a part of the requirements of this document.

E.2.1 NFPA Publications. National Fire Protection Association, 1 Batterymarch Park, Quincy, MA 02169-7471.

Fire Protection Handbook, 20th edition, 2008.

Fire and Life Safety Inspection Manual, 2012.

National Fire Codes[®], 2017.

E.2.2 Other Publications.

E.2.2.1 ANSI Publications. American National Standards Institute, Inc., 25 West 43rd Street, 4th Floor, New York, NY 10036.

ANSI/NEMA Z535.1, *American National Standard for Safety Colors*, 2011.

ANSI/NEMA Z535.3, *American National Standard Criteria for Safety Symbols*, 2011.

ANSI/NEMA Z535.4, *American National Standard for Product Safety Signs and Labels*, 2011.

E.2.2.2 ISO Publications. International Organization for Standardization, ISO Central Secretariat, BIBC II, 8, Chemin de Blandonnet, CP 401, 1214 Vernier, Geneva, Switzerland.

ISO 3864, *Safety Colors and Safety Signs*, 1984.

ISO 6309, *Fire Protection — Safety Signs*, 1987.

ISO 6790, *Equipment for Fire Protection and Fire Fighting Graphical Symbols for Fire Protection Plans — Specification*, 1986.

ISO 7010, *Graphical Symbols – Safety Colours And Safety Signs – Registered Safety Signs*, 2011.

E.3 References for Extracts in Informational Sections.

NFPA 1, *Fire Code*, 2015 edition.

Index

Copyright © 2017 National Fire Protection Association. All Rights Reserved.

The copyright in this index is separate and distinct from the copyright in the document that it indexes. The licensing provisions set forth for the document are not applicable to this index. This index may not be reproduced in whole or in part by any means without the express written permission of NFPA.

- A-**
- Additional Explanatory Information on Chapters 1 Through 6, Annex B**
- Additional Explanatory Information on Chapter 4, B.3
 - Symbol Testing, B.3.1
 - Additional Explanatory Information on Chapter 5, B.4
 - Symbol Testing, B.4.1
 - Additional Explanatory Information on Chapter 6, B.5
 - Discussion of Basic Symbols, B.5.2
 - Symbol Testing, B.5.2.1
 - Symbol Selection Procedure, B.5.1
 - Use of Color Coding, B.5.3
 - General, B.5.3.1
- Administration, Chap. 1**
- Equivalency, 1.4
 - Purpose, 1.2
 - Retroactivity, 1.3
 - Scope, 1.1
 - Units, 1.5
- Approved**
- Definition, 3.2.1
- Authority Having Jurisdiction (AHJ)**
- Definition, 3.2.2, A.3.2.2
- D-**
- Definitions, Chap. 3**
- E-**
- Emergency Evacuation Diagrams and Plans, Chap. 11**
- Composition, 11.2
 - Construction, 11.5
 - Materials, 11.5.1
 - Information Shown, 11.4
 - Introduction, 11.1
 - Orientation, 11.3, A.11.3
- Emergency Responder Map, Annex C**
- Emergency Responder Plan, C.1
- Explanatory Material, Annex A**
- F-**
- Fire Fighter Safety Building Marking System, Annex D**
- Fire Fighter Safety Building Marking System (FFSBMS). [1:E.1], D.1
 - General. [1:E.1.1], D.1.1
 - Ratings. [1:E.1.3], D.1.3
 - Automatic Fire Sprinkler and Standpipe System, D.1.3.4
 - Construction Type, D.1.3.2
 - Hazards of Contents, D.1.3.3
 - Occupancy/Life Safety Issues, D.1.3.5
 - Special Designations, D.1.3.6
 - Sign. [1:E.1.2], D.1.2
 - Notes, D.2
 - Note 1, D.2.1
 - Note 2, D.2.2
 - Note 3, D.2.3
 - Note 4, D.2.4
- I-**
- Informational References, Annex E**
- L-**
- Labeled**
- Definition, 3.2.3
- Listed**
- Definition, 3.2.4, A.3.2.4
- P-**
- Photoluminescent**
- Definition, 3.3.1
- Pre-Incident Planning**
- Definition, 3.3.2
- R-**
- Referenced Publications, Chap. 2**
- Referent**
- Definition, 3.3.3, A.3.3.3
- S-**
- Self-Luminous (Emergency Symbols)**
- Definition, 3.3.4
- Shall**
- Definition, 3.2.5
- Should**
- Definition, 3.2.6
- Standard**
- Definition, 3.2.7
- Supplementary Indicators**
- Definition, 3.3.5, A.3.3.5
- Symbol**
- Definition, 3.3.6, A.3.3.6
- Symbology for Emergency Management Mapping, Chap. 10**
- Damage Operational Symbols, 10.1
 - Incidents Symbology, 10.3
 - Infrastructures Symbology, 10.5
 - Natural Events Symbology, 10.4
 - Operations Symbology, 10.2
- Symbols for General Use, Chap. 4**
- Class of Fire Symbols, 4.3
 - Introduction, 4.1
 - Purpose, 4.1.2

- Symbol Presentation, 4.1.3, A.4.1.3
 - Symbol Color, 4.1.3.3
- Symbols for General Use, 4.2, A.4.2
- Symbols for Use by the Fire Service**, Chap. 5
 - Fire Apparatus Safety Symbols, 5.3
 - Introduction, 5.1
 - Symbol Presentation, 5.1.3, A.5.1.3
 - Symbol Background, 5.1.3.2
 - Symbol Color, 5.1.3.3
 - Symbol Orientation, 5.1.3.4
 - Symbol Shapes, 5.1.3.1, A.5.1.3.1
 - Symbols for Use by the Fire Service, 5.2, A.5.2
- Symbols for Use in Architectural and Engineering Drawings and Insurance Diagrams**, Chap. 6
 - Introduction, 6.1, A.6.1
 - Symbol Presentation, 6.1.2, A.6.1.2
 - Screened Lines, 6.1.2.2
 - Symbol Orientation, 6.1.2.4, A.6.1.2.4
 - Symbol Scale, 6.1.2.3
 - Symbol Shapes, 6.1.2.1, A.6.1.2.1
 - Symbols for Building Construction, 6.3
 - Height, 6.3.2, A.6.3.2
 - Miscellaneous Features, 6.3.6
 - Special Symbols for Cross-Sections, 6.3.5, A.6.3.5
 - Symbols for Floor Openings, Wall Openings, Roof Openings, and Their Protection, 6.3.4
 - Symbols for Walls and Parapets, 6.3.3, A.6.3.3
 - Types of Building Construction, 6.3.1, A.6.3.1
 - Symbols for Site Features, 6.2
 - Bodies of Water, 6.2.4, A.6.2.4
 - Buildings, 6.2.1
 - Fences, 6.2.5
 - Fire Department Access, 6.2.7
 - Other Site Features, 6.2.8
 - Property Lines, 6.2.6
 - Railroad Tracks, 6.2.2
 - Streets, 6.2.3, A.6.2.3
- Symbols for Use in Electronic Fire and Smoke Detection and Notification System Drawings and Insurance Diagrams**, Chap. 8
 - Introduction, 8.1, A.8.1
 - Symbol Presentation, 8.1.2, A.8.1.2
 - Screened Lines, 8.1.2.2
 - Symbol Orientation, 8.1.2.4, A.8.1.2.4
 - Symbol Scale, 8.1.2.3
 - Symbol Shapes, 8.1.2.1, A.8.1.2.1
 - Notification Appliances, 8.4
 - Emergency Communications Notification Appliances, 8.4.3
 - Notification Appliances, 8.4.2
 - Related Equipment, 8.5
 - Symbols for Control Panels, 8.2
 - Symbols for Fire Alarms, Detection, and Related Equipment — Signal Initiating Devices and Activation Switches, 8.3, A.8.3
 - Symbols for Smoke/Pressurization Control, 8.6
- Symbols for Use in Pre-Incident Planning Sketches**, Chap. 9
 - Access Features, Assessment Features, Ventilation Features, and Utility Shutoffs, 9.2, A.9.2
 - Detection/Extinguishing Equipment, 9.3
 - Equipment Rooms, 9.5
 - Identification of Hazardous Materials, 9.6, A.9.6
 - Introduction, 9.1
 - Symbol Shapes, 9.1.2, A.9.1.2
 - Water Flow Control Valves and Water Sources, 9.4
- Symbols for Use in Water Supply, Extinguishing, and Sprinkler System Drawings and Insurance Diagrams**, Chap. 7
 - Indicating Appliances, 7.5
 - Introduction, 7.1, A.7.1
 - Symbol Presentation, 7.1.2, A.7.1.2
 - Screened Lines, 7.1.2.2
 - Symbol Orientation, 7.1.2.4, A.7.1.2.4
 - Symbol Scale, 7.1.2.3
 - Symbol Shapes, 7.1.2.1, A.7.1.2.1
 - Miscellaneous Symbols, 7.9, A.7.9
 - Symbols for Fire Extinguishing Systems, 7.6, A.7.6
 - Symbols for Fire Sprinklers, 7.6.2
 - Symbols for Piping, Valves, Control Devices, and Hangers, 7.6.3, A.7.6.3
 - Various Types of Fire Extinguishing Systems, 7.6.1
 - Dry Chemical Systems, 7.6.1.2
 - Supplementary Symbols, 7.6.1.4
 - Systems Utilizing a Gaseous Medium, 7.6.1.3
 - Water-Based Systems, 7.6.1.1
 - Symbols for Fire-Fighting Equipment, 7.8
 - Symbols for Portable Fire Extinguishers, 7.7
 - Symbols Related to Means of Egress, 7.4
 - Water Supply and Distribution Symbols, 7.2, A.7.2

Sequence of Events for the Standards Development Process

Once the current edition is published, a Standard is opened for Public Input.

Step 1 – Input Stage

- Input accepted from the public or other committees for consideration to develop the First Draft
- Technical Committee holds First Draft Meeting to revise Standard (23 weeks); Technical Committee(s) with Correlating Committee (10 weeks)
- Technical Committee ballots on First Draft (12 weeks); Technical Committee(s) with Correlating Committee (11 weeks)
- Correlating Committee First Draft Meeting (9 weeks)
- Correlating Committee ballots on First Draft (5 weeks)
- First Draft Report posted on the document information page

Step 2 – Comment Stage

- Public Comments accepted on First Draft (10 weeks) following posting of First Draft Report
- If Standard does not receive Public Comments and the Technical Committee chooses not to hold a Second Draft meeting, the Standard becomes a Consent Standard and is sent directly to the Standards Council for issuance (see Step 4) or
- Technical Committee holds Second Draft Meeting (21 weeks); Technical Committee(s) with Correlating Committee (7 weeks)
- Technical Committee ballots on Second Draft (11 weeks); Technical Committee(s) with Correlating Committee (10 weeks)
- Correlating Committee Second Draft Meeting (9 weeks)
- Correlating Committee ballots on Second Draft (8 weeks)
- Second Draft Report posted on the document information page

Step 3 – NFPA Technical Meeting

- Notice of Intent to Make a Motion (NITMAM) accepted (5 weeks) following the posting of Second Draft Report
- NITMAMs are reviewed and valid motions are certified by the Motions Committee for presentation at the NFPA Technical Meeting
- NFPA membership meets each June at the NFPA Technical Meeting to act on Standards with “Certified Amending Motions” (certified NITMAMs)
- Committee(s) vote on any successful amendments to the Technical Committee Reports made by the NFPA membership at the NFPA Technical Meeting

Step 4 – Council Appeals and Issuance of Standard

- Notification of intent to file an appeal to the Standards Council on Technical Meeting action must be filed within 20 days of the NFPA Technical Meeting
- Standards Council decides, based on all evidence, whether to issue the standard or to take other action

Notes:

1. Time periods are approximate; refer to published schedules for actual dates.
2. Annual revision cycle documents with certified amending motions take approximately 101 weeks to complete.
3. Fall revision cycle documents receiving certified amending motions take approximately 141 weeks to complete.

Committee Membership Classifications^{1,2,3,4}

The following classifications apply to Committee members and represent their principal interest in the activity of the Committee.

1. M *Manufacturer*: A representative of a maker or marketer of a product, assembly, or system, or portion thereof, that is affected by the standard.
2. U *User*: A representative of an entity that is subject to the provisions of the standard or that voluntarily uses the standard.
3. IM *Installer/Maintainer*: A representative of an entity that is in the business of installing or maintaining a product, assembly, or system affected by the standard.
4. L *Labor*: A labor representative or employee concerned with safety in the workplace.
5. RT *Applied Research/Testing Laboratory*: A representative of an independent testing laboratory or independent applied research organization that promulgates and/or enforces standards.
6. E *Enforcing Authority*: A representative of an agency or an organization that promulgates and/or enforces standards.
7. I *Insurance*: A representative of an insurance company, broker, agent, bureau, or inspection agency.
8. C *Consumer*: A person who is or represents the ultimate purchaser of a product, system, or service affected by the standard, but who is not included in (2).
9. SE *Special Expert*: A person not representing (1) through (8) and who has special expertise in the scope of the standard or portion thereof.

NOTE 1: “Standard” connotes code, standard, recommended practice, or guide.

NOTE 2: A representative includes an employee.

NOTE 3: While these classifications will be used by the Standards Council to achieve a balance for Technical Committees, the Standards Council may determine that new classifications of member or unique interests need representation in order to foster the best possible Committee deliberations on any project. In this connection, the Standards Council may make such appointments as it deems appropriate in the public interest, such as the classification of “Utilities” in the National Electrical Code Committee.

NOTE 4: Representatives of subsidiaries of any group are generally considered to have the same classification as the parent organization.

Submitting Public Input / Public Comment Through the Online Submission System

Soon after the current edition is published, a Standard is open for Public Input.

Before accessing the Online Submission System, you must first sign in at www.nfpa.org. *Note: You will be asked to sign-in or create a free online account with NFPA before using this system:*

- a. Click on Sign In at the upper right side of the page.
- b. Under the Codes and Standards heading, click on the “List of NFPA Codes & Standards,” and then select your document from the list or use one of the search features.

OR

- a. Go directly to your specific document information page by typing the convenient shortcut link of www.nfpa.org/document# (Example: NFPA 921 would be www.nfpa.org/921). Sign in at the upper right side of the page.

To begin your Public Input, select the link “The next edition of this standard is now open for Public Input” located on the About tab, Current & Prior Editions tab, and the Next Edition tab. Alternatively, the Next Edition tab includes a link to Submit Public Input online.

At this point, the NFPA Standards Development Site will open showing details for the document you have selected. This “Document Home” page site includes an explanatory introduction, information on the current document phase and closing date, a left-hand navigation panel that includes useful links, a document Table of Contents, and icons at the top you can click for Help when using the site. The Help icons and navigation panel will be visible except when you are actually in the process of creating a Public Input.

Once the First Draft Report becomes available there is a Public Comment period during which anyone may submit a Public Comment on the First Draft. Any objections or further related changes to the content of the First Draft must be submitted at the Comment stage.

To submit a Public Comment you may access the online submission system utilizing the same steps as previously explained for the submission of Public Input.

For further information on submitting public input and public comments, go to: <http://www.nfpa.org/publicinput>.

Other Resources Available on the Document Information Pages

About tab: View general document and subject-related information.

Current & Prior Editions tab: Research current and previous edition information on a Standard.

Next Edition tab: Follow the committee’s progress in the processing of a Standard in its next revision cycle.

Technical Committee tab: View current committee member rosters or apply to a committee.

Technical Questions tab: For members and Public Sector Officials/AHJs to submit questions about codes and standards to NFPA staff. Our Technical Questions Service provides a convenient way to receive timely and consistent technical assistance when you need to know more about NFPA codes and standards relevant to your work. Responses are provided by NFPA staff on an informal basis.

Products & Training tab: List of NFPA’s publications and training available for purchase.

Information on the NFPA Standards Development Process

I. Applicable Regulations. The primary rules governing the processing of NFPA standards (codes, standards, recommended practices, and guides) are the NFPA *Regulations Governing the Development of NFPA Standards (Regs)*. Other applicable rules include NFPA *Bylaws*, NFPA *Technical Meeting Convention Rules*, NFPA *Guide for the Conduct of Participants in the NFPA Standards Development Process*, and the NFPA *Regulations Governing Petitions to the Board of Directors from Decisions of the Standards Council*. Most of these rules and regulations are contained in the *NFPA Standards Directory*. For copies of the *Directory*, contact Codes and Standards Administration at NFPA Headquarters; all these documents are also available on the NFPA website at “www.nfpa.org.”

The following is general information on the NFPA process. All participants, however, should refer to the actual rules and regulations for a full understanding of this process and for the criteria that govern participation.

II. Technical Committee Report. The Technical Committee Report is defined as “the Report of the responsible Committee(s), in accordance with the Regulations, in preparation of a new or revised NFPA Standard.” The Technical Committee Report is in two parts and consists of the First Draft Report and the Second Draft Report. (See *Regs* at Section 1.4.)

III. Step 1: First Draft Report. The First Draft Report is defined as “Part one of the Technical Committee Report, which documents the Input Stage.” The First Draft Report consists of the First Draft, Public Input, Committee Input, Committee and Correlating Committee Statements, Correlating Notes, and Ballot Statements. (See *Regs* at 4.2.5.2 and Section 4.3.) Any objection to an action in the First Draft Report must be raised through the filing of an appropriate Comment for consideration in the Second Draft Report or the objection will be considered resolved. [See *Regs* at 4.3.1(b).]

IV. Step 2: Second Draft Report. The Second Draft Report is defined as “Part two of the Technical Committee Report, which documents the Comment Stage.” The Second Draft Report consists of the Second Draft, Public Comments with corresponding Committee Actions and Committee Statements, Correlating Notes and their respective Committee Statements, Committee Comments, Correlating Revisions, and Ballot Statements. (See *Regs* at 4.2.5.2 and Section 4.4.) The First Draft Report and the Second Draft Report together constitute the Technical Committee Report. Any outstanding objection following the Second Draft Report must be raised through an appropriate Amending Motion at the NFPA Technical Meeting or the objection will be considered resolved. [See *Regs* at 4.4.1(b).]

V. Step 3a: Action at NFPA Technical Meeting. Following the publication of the Second Draft Report, there is a period during which those wishing to make proper Amending Motions on the Technical Committee Reports must signal their intention by submitting a Notice of Intent to Make a Motion (NITMAM). (See *Regs* at 4.5.2.) Standards that receive notice of proper Amending Motions (Certified Amending Motions) will be presented for action at the annual June NFPA Technical Meeting. At the meeting, the NFPA membership can consider and act on these Certified Amending Motions as well as Follow-up Amending Motions, that is, motions that become necessary as a result of a previous successful Amending Motion. (See 4.5.3.2 through 4.5.3.6 and Table 1, Columns 1-3 of *Regs* for a summary of the available Amending Motions and who may make them.) Any outstanding objection following action at an NFPA Technical Meeting (and any further Technical Committee consideration following successful Amending Motions, see *Regs* at 4.5.3.7 through 4.6.5.3) must be raised through an appeal to the Standards Council or it will be considered to be resolved.

VI. Step 3b: Documents Forwarded Directly to the Council. Where no NITMAM is received and certified in accordance with the Technical Meeting Convention Rules, the standard is forwarded directly to the Standards Council for action on issuance. Objections are deemed to be resolved for these documents. (See *Regs* at 4.5.2.5.)

VII. Step 4a: Council Appeals. Anyone can appeal to the Standards Council concerning procedural or substantive matters related to the development, content, or issuance of any document of the NFPA or on matters within the purview of the authority of the Council, as established by the Bylaws and as determined by the Board of Directors. Such appeals must be in written form and filed with the Secretary of the Standards Council (see *Regs* at Section 1.6). Time constraints for filing an appeal must be in accordance with 1.6.2 of the *Regs*. Objections are deemed to be resolved if not pursued at this level.

VIII. Step 4b: Document Issuance. The Standards Council is the issuer of all documents (see Article 8 of *Bylaws*). The Council acts on the issuance of a document presented for action at an NFPA Technical Meeting within 75 days from the date of the recommendation from the NFPA Technical Meeting, unless this period is extended by the Council (see *Regs* at 4.7.2). For documents forwarded directly to the Standards Council, the Council acts on the issuance of the document at its next scheduled meeting, or at such other meeting as the Council may determine (see *Regs* at 4.5.2.5 and 4.7.4).

IX. Petitions to the Board of Directors. The Standards Council has been delegated the responsibility for the administration of the codes and standards development process and the issuance of documents. However, where extraordinary circumstances requiring the intervention of the Board of Directors exist, the Board of Directors may take any action necessary to fulfill its obligations to preserve the integrity of the codes and standards development process and to protect the interests of the NFPA. The rules for petitioning the Board of Directors can be found in the *Regulations Governing Petitions to the Board of Directors from Decisions of the Standards Council* and in Section 1.7 of the *Regs*.

X. For More Information. The program for the NFPA Technical Meeting (as well as the NFPA website as information becomes available) should be consulted for the date on which each report scheduled for consideration at the meeting will be presented. To view the First Draft Report and Second Draft Report as well as information on NFPA rules and for up-to-date information on schedules and deadlines for processing NFPA documents, check the NFPA website (www.nfpa.org/docinfo) or contact NFPA Codes & Standards Administration at (617) 984-7246.



Xchange™

The place to connect online with your fire, electrical, and life safety peers

Have a question about the code or standard you're reading now?

NFPA Xchange™ can help!

NFPA Xchange™ brings together over 30,000 professionals worldwide, asking and answering each other's questions, sharing ideas, and discussing the issues impacting your industry today.

NFPA Xchange™ is free to join and offers:

- A robust collection of previously asked and answered questions to search
- Access to thousands of peers for problem-solving and on-the-job advice
- NFPA blogs, white papers, and webinars in one convenient place

NFPA members also enjoy Xchange™ **Members Only**, the online space for technical questions* answered by NFPA staff, exclusive NFPA live events, and premier access to curated content.

Join NFPA Xchange™ TODAY!

www.nfpa.org/xchange

Xchange Today. Safer Tomorrow.

*For the full terms of use, please visit nfpa.org/standard_items/terms-of-use#xchange. NFPA® is a registered trademark of the National Fire Protection Association, Quincy, MA 02169.



 <https://edufire.ir>



@EDUFIRE_IR



@EDUFIRE.IR

برای مشاهده ویدیوهای آموزشی بیشتر به سایت و کانال تلگرامی ما مراجعه نمایید.

✓ ارائه آموزش‌های تخصصی حوزه حریق (زبان اصلی و فارسی)

✓ پکیج رایگان تمامی استانداردهای NFPA 2019

✓ ارائه نرم‌افزار اتواسپرینک (۲۰۱۸)

✓ مقالات حوزه حریق

✓ کدهای تخفیف

✓ و

با ما همراه باشید.

[EDUFIRE.IR](https://edufire.ir)

آموزش تخصصی حریق

Follow us for more contact:

Telegram : @Edufire_ir

Instagram: @Edufire.ir

Aparat: Edufire.ir